

TRUSTED
SINCE 1958
WORLDWIDE

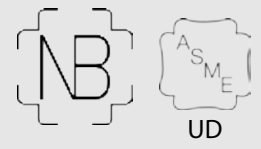

FROM THE
CREATORS
OF THE
Original
BUCKLING
PIN
VALVE

Precise.

Quality.

Reliable.



MODEL CC-ASME ADVANTAGES

- Visual and remote indication of opening
- No fugitive emissions, even on resetting
- Does not generate metal or plastic shards
- Unaffected by changing ambient temperatures on the pin
- Bubble-tight seal to set point
- Opens in milliseconds
- Operates to within 95% of set point
- Pin cannot fatigue and buckle early
- Precise pin, obeying Euler's Law, acts as a pressure sensor and actuator
- The valve is downstream balanced so that downstream pressure does not affect set point

ASME SCOPE

Pressure Ranges: 15 - 1480 psi*
Rated for Both Liquid and Air Media

*Varies depending on Inlet/Outlet Sizes

ITEM NO.	DESCRIPTION	STANDARD MATERIAL
1	PISTON	SA-564 17-4SS COND. HH1150
2	NOZZLE	SA479-316
3	VALVE BODY	SA216 WCC
4	BONNET	SA479-316
5	TOP PLATE	SA105
6	HOLDING NUT	SA-564 17-4SS COND. HH1150
7	BREATHER VENT	316SS
8	HEX NUT	SA194 2H
9	STUD	SA193-B7
10	DRAIN PLUG	SA105
11	BODY PLUG	SA479-316
12	GASKET (NOZZLE)	SA240-316
13	GASKET (PLUG)	SA240-316
14	GASKET (BONNET)	SA240-316
15	BONNET O-RING	SPECIFY
16	PISTON O-RING	SPECIFY
17	POST	SA193-B7
18	SPACER	SA213-316
19	RUPTURE PIN	PROPRIETARY ALLOY

Consult factory for alternative materials.

APPLICATIONS

Provides safety for a wide variety of pressure relief applications. The ideal substitute for rupture discs.

OPERATION

In the closed position, an elastomer seal contacts a machined, stainless-steel piston seat for a bubble-tight shut off. When the pin buckles, the piston moves off seat to allow full flow pressure relief.

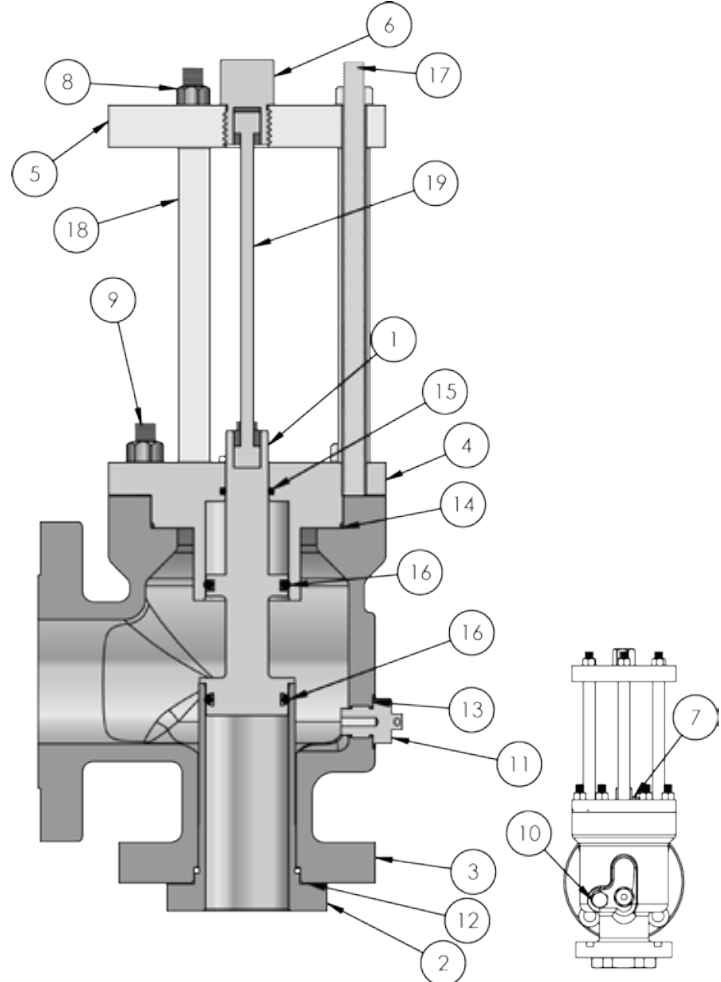
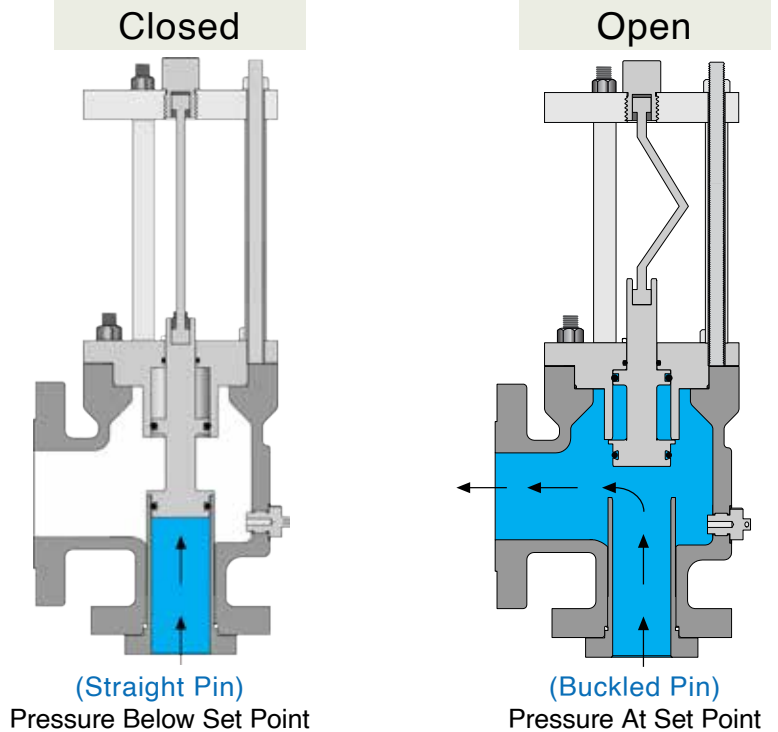

The **Model CC-ASME** holds a bubble-tight, closed position until pressure reaches an exact set point. At set point, the valve instantly opens to relieve pressure from a protected system.

- Wide variety of pressures ratings and settings.
- Large orifice sizes.
- Reliable settings.
- Utilizes proven design principle – Euler’s Law.
- Provides bubble-tight seal in closed position.
- +/- 5% accuracy of set pressure.
- Stainless-steel seat and piston – standard.
- Manually reseal rapidly without opening the line to atmosphere.
- Pin label shows the pin code, valve serial number and pin set point in PSIG.
- No loose metal or plastic shards to enter the flow stream upon opening.
- One moving part.
- The pin cannot fatigue.
- Provides a reliable signal with a proximity sensor to monitor the stem movement and gives a remote indication that the valve has opened (Option).
- Spare pins can be stored at the valve (Option).
- Balanced piston design to compensate for the effects of back pressure.

SPECIFICATIONS

VALVE POSITION

Pins are sized with the valve oriented as it will be in actual use; so, piston weight will not affect set point.

PRESSURE SET POINT RANGE

15 to 1,480 PSI.

SIZES

1 X 2” to 8 X 10”

CONNECTIONS

Flange connections available - 150# to 600#. (see chart)

VALVE SEALS

Available for high and low temperatures, FKM standard.

STANDARD MATERIALS

ASME Section II materials.

ACCURACY

± 5% above 40 PSI, ±2 PSI at 40 PSI and below.

DOWNSTREAM PRESSURE

BALANCED

The piston balances out downstream pressure.

DIMENSIONS

API-526 Spring-Relief valve dimensions.

OPTIONS

PROXIMITY SENSOR

For remote open indication.

PIN HOLDER

Pin storage at the valve.

STAINLESS-STEEL SAFETY CAGE

Protects your pin from accidental damage.

AIR FLOW CAPACITY VS. PRESSURE (FOR CONDITIONS SHOWN BELOW)							
Valve	1 x 2	1.5 x 2	2 x 3	3 x 4	4 x 6	6 x 8	8 x 10
ORIFICE DIA. (IN.)	0.859	1.335	1.939	2.443	3.826	5.761	7.156
ORIFICE AREA (SQ. IN.)	0.580	1.400	2.953	4.687	11.497	26.067	40.219
SLOPE	9.0	21.6	45.6	72.4	177.7	402.8	621.5
Kd FACTOR	0.843	0.843	0.843	0.843	0.843	0.843	0.843
SET PRESSURE (PSIG)	CAPACITY IN SCFM. OVERPRESSURE = 110% OR 3 PSI, WHICHEVER IS GREATER						
15	293	707	1492	2368	5809	13172	20323
20	337	815	1720	2730	6697	15186	23430
25	382	923	1948	3092	7586	17200	26538
30	427	1031	2176	3454	8474	19214	29645
50	624	1507	3180	5048	12383	28076	43318
75	871	2102	4435	7040	17268	39153	60410
100	1117	2697	5690	9031	22154	50230	77501
150	1610	3887	8200	13015	31926	72385	111684
200	2103	5077	10710	16998	41697	94540	145867
250	2596	6267	13219	20982	51469	116695	180050
285	2941	7100	14976	23770	58309	132203	203978
300	3089	7457	15729	24966	61240		
350	3582	8647	18239	28949	71012		
400	4075	9837	20749	32933	80783		
450	4568	11026	23259	36916	90555		
500	5061	12216	25768	40900	100326		
550	5554	13406	28278	44883	110098		
600	6047	14596	30788	48867	119869		
650	6540	15786	33298	52850	129641		
700	7033	16976	35808	56834	139412		
740	7427	17928	37815	60021	147229		
800	8018	19356					
900	9004	21735					
1000	9990	24115					
1100	10976	26495					
1200	11962	28875					
1300	12948	31254					
1400	13934	33634					
1480	14723	35538					

Conditions						
Temp (°F)	Baro. (psi)	Cp/Cv	Comp. Factor	MW	Density	Gas Const.
60	14.7	1.4	1	28.97	0.0764	356

WATER FLOW CAPACITY VS. PRESSURE (FOR CONDITIONS SHOWN BELOW)							
Valve	1 x 2	1.5 x 2	2 x 3	3 x 4	4 x 6	6 x 8	8 x 10
ORIFICE DIA. (IN.)	0.859	1.335	1.939	2.443	3.826	5.761	7.156
ORIFICE AREA (SQ. IN.)	0.580	1.400	2.953	4.687	11.497	26.067	40.219
FLOW FACTOR	16.6	40.1	84.5	134.1	329.0	745.9	1150.8
Kd FACTOR	0.753	0.753	0.753	0.753	0.753	0.753	0.753
SET PRESSURE (PSIG)	CAPACITY IN GPM. OVERPRESSURE = 110% OR 3 PSI, WHICHEVER IS GREATER						
15	70	169	358	568	1395	3164	4882
20	79	192	405	643	1577	3577	5519
25	87	211	447	709	1740	3946	6089
30	95	230	485	770	1889	4284	6610
50	123	297	626	994	2439	5531	8534
75	150	363	767	1218	2987	6774	10452
100	174	420	886	1406	3450	7822	12069
150	213	514	1085	1722	4225	9580	14782
200	246	594	1253	1989	4879	11062	17068
250	275	664	1401	2223	5455	12368	19083
285	293	709	1496	2374	5824	13206	20375
300	301	727	1534	2436	5975		
350	325	786	1657	2631	6454		
400	348	840	1772	2813	6900		
450	369	891	1879	2983	7319		
500	389	939	1981	3145	7714		
550	408	985	2078	3298	8091		
600	426	1029	2170	3445	8451		
650	443	1071	2259	3586	8796		
700	460	1111	2344	3721	9128		
740	473	1142	2410	3826	9385		
800	492	1188					
900	522	1260					
1000	550	1328					
1100	577	1393					
1200	602	1455					
1300	627	1514					
1400	651	1572					
1480	669	1616					

Conditions					
Temp (°F)	Baro. (psi)	SG	Back Pressure	Kv	Specific Weight
70	14.7	1	0	1	62.3058



Taylor Valve Technology
 8300 S.W. 8th Street
 Oklahoma City, Oklahoma 73128

TEL 405.787.0145

FAX 800.805.3401

WEB www.taylorvalve.com

EMAIL info@taylorvalve.com



Precise.

Quality.

Reliable.

Rupture Pin Model CC-ASME Nomenclature

CC-	A	B	C	D	E	F	G	H
	Inlet x Outlet	Connections	Inlet x Outlet Rating	Material Body/ Inlet/Outlet/Bonnet	Stem Material	Trim (Inlet and Piston head)	Piston Groove Design	Seal Material
CC-	A	B	C	D	E	F	G	H
	1"x2"	RFF x RFF 1	150# x 150# 1	CS 1	17-4 1	316 1	Square 1	FKM 1
	1.5"x2"	RTJ x RFF 3	300# x 150# 2	316 3				NBR 3
	2"x3"		600# x 150# 3					EPDM 6
	3"x4"							
	4"x6"							
	6"x8"							
	8"x10"							

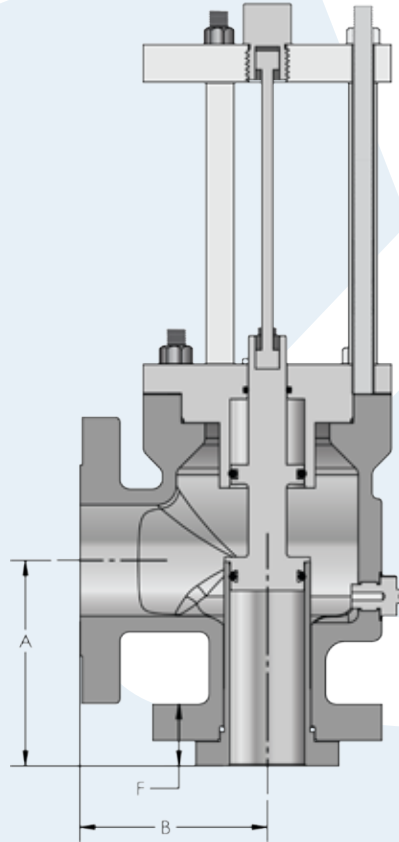

Inlet x Outlet	Connections		Dimensions (in)			Aprox. Weight	
	Flange Rating	MaxSet (psig)	A	B	F	lbs	kg
1x2	150x150	285	4-1/8	4-1/2	1-5/16	50	23
	300x150	740			1-3/8		
	600x150	1480					
1.5x2	150x150	285	4-7/8	4-3/4	1-5/16	63	29
	300x150	740	4-7/8	6	1-9/16		
	600x150	1480					
2x3	150x150	285	5-3/8	4-7/8	1-3/8	70	32
	300x150	740			1-9/16		
3x4	150x150	285	6-1/8	6-1/2	1-5/8	133	60
	300x150	740			1-13/16		
4x6	150x150	285	7-1/8	9	1-5/8	214	97
	300x150	740			1-15/16		
6x8	150x150	285	9-7/16	9-1/2	1-13/16	373	169
8x10	150x150	285	10-7/8	11	1-7/8	448	203