

BRASS SERIES

Safety Relief Valves

TRUSTED
SINCE 1958
WORLDWIDE

Precise.

Quality.

Reliable.



Table of Contents

Model Series 69

Overview	3
Bill of Materials & Dimensions	4
Part Number System	5
Capacity Chart	5
Lift Lever Option	5

Model Series 88/89

Overview	6
Bill of Materials & Dimensions	7
Capacity Charts	8
Soft Seat & Lift Lever Option	9
Part Number System	9

Model Series 560/570

Overview	10
Bill of Materials & Dimensions	11
Part Number System	12
560 Steam Capacity Charts	12
570 Steam Capacity Charts	13



Series 69

The Aquatrol Series 69 is an industry standard relief valve used for liquid relief and by-pass. Engineered and designed for heavy duty, industrial and commercial usages. A single piece bonnet to eliminate leakage while allowing for simple cleaning. Easy removable sealed hex-cap to adjust pressure.

Valves are calibrated (set to pressure) based on a range of flow-rates (GPM) versus seat size and set pressure. Standard valve is set to pressure to achieve flow rate maximum and minimums within each set pressure range. See capacity chart for details.

Usages:

Include liquid by-pass, regulation, continuous relief and over-protection. Used on pumping stations, tanks, hydraulics, fluid / piping lines, oil fields, gas lines and more where a Liquid or Water Relief Valve is needed.

Features:

- Field adjustable by simple removal of the hex-cap
- Metal to metal precision lapped seating
- Back pressure tested
- Ease of cleaning and maintenance with simple bonnet removal.
- Stainless steel springs
- Single piece - 100% leak free bonnet



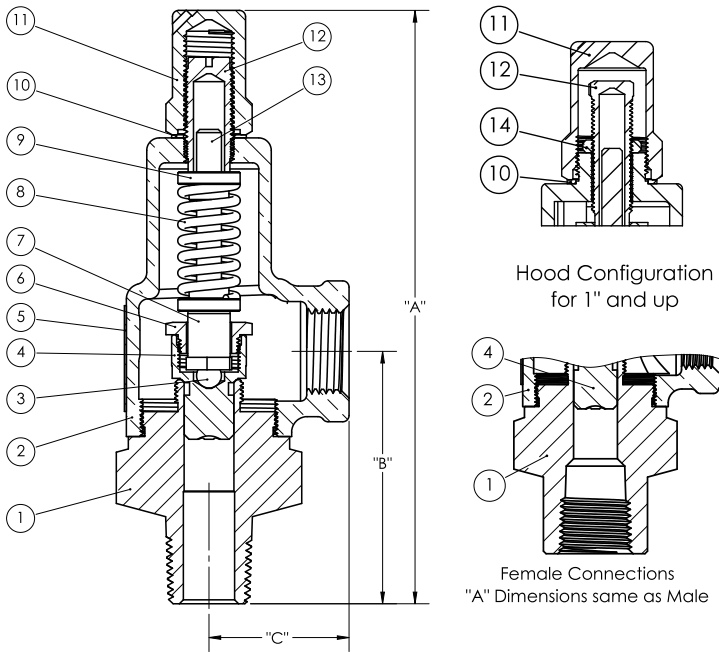

SERIES 69		
Item	Description	Brass Option
1	Body	B16/B283
2	Bonnet	B584
3	Ball	Stainless
4	Disc	B62
5	Nameplate	Stainless
6	Disc Nut	B16
7	Spring Support	B16
8	Spring	302/17-7
9	Spring Plate	B16
10	Hood Seal	PTFE
11	Hood	B16
12	Pressure Screw	B16
13	Spring Post	B16
14	Lock-nut	B16

SERIES 69 - Dimensions								
Series	Size I.D.	Inlet	Outlet	DN	Dimension - In. (mm)			Weight Lb - (Kg)
					A	B	C	
69	A1	1/2"	1/2"	15	6" (152)	2-1/2" (64)	1-3/8" (35)	1.7 (0.8)
69	A1	1/2"	3/4"	15	6" (152)	2-1/2" (64)	1-3/8" (35)	1.7 (0.8)
69	B2	3/4"	1"	20	6-1/4" (159)	2-5/8" (67)	1-1/2" (38)	2.2 (1)
69	C1	1"	1"	25	7-3/8" (187)	2-7/8" (73)	1-3/4" (44)	3 (1.4)
69	C2	1"	1-1/4"	25	7-3/8" (187)	2-7/8" (73)	1-3/4" (44)	3 (1.4)
69	D1	1-1/4"	1-1/4"	32	8-1/4" (210)	3-3/8" (86)	2" (51)	4 (1.8)
69	D2	1-1/4"	1-1/2"	32	8-1/4" (210)	3-3/8" (86)	2" (51)	4 (1.8)
69	E1	1-1/2"	1-1/2"	40	9-1/2" (241)	3-1/2" (89)	2-1/8" (54)	5.8 (2.6)
69	E2	1-1/2"	2"	40	9-1/2" (241)	3-1/2" (89)	2-1/8" (54)	5.8 (2.6)
69	F1	2"	2"	50	11" (279)	3-7/8" (98)	2-5/8" (67)	9.7 (4.4)
69	F2	2"	2-1/2"	50	11" (279)	3-7/8" (98)	2-5/8" (67)	9.7 (4.4)
69	G1	2-1/2"	2-1/2"	65	13" (330)	5-1/4" (133)	3-5/8" (92)	19 (8.6)
69	G2	2-1/2"	3"	65	13" (330)	5-1/4" (133)	3-5/8" (92)	19 (8.6)
69	H1	3"	3"	80	13-1/4" (337)	5-5/8" (143)	3-5/8" (92)	19 (8.6)



SERIES 69 - PART NUMBER									
69	C	1	A	1	M	2	U	1	125
Series	Inlet	Outlet	Metals	Connection	Seating	Cap	Service	Options	Set
69	A - 1/2"	1 - Same Size as Inlet	A - Brass/Bronze	1 - NPT Mx F	M - Metal	2 - Closed Cap	U - Non-Code Liquid	1 - None	Ex. 125
	B - 3/4"								
	C - 1"	2 - Next Larger than Inlet							
	D - 1-1/4"								
	E - 1-1/2"								
	F - 2"								
	G - 2-1/2"								
	H - 3"								

SERIES 69 LIQUID CAPACITY GPM AT 25% OVER SET PRESSURE

Flow Factor	1.586	3.088	4.820	6.821	8.769	13.019	17.540	22.135
PSI	A 1/2"	B 3/4"	C 1"	"D 1-1/4"	"E 1-1/2"	F 2"	"G 2-1/2"	H 3"
5	4.0	8	12	17	22	33	44	55
10	5.6	11	17	24	31	46	62	78
20	7.9	15	24	34	44	65	88	111
30	9.7	19	30	42	54	80	107	136
40	11.2	22	34	48	62	92	124	157
50	12.5	24	38	54	69	103	139	175
60	13.7	27	42	59	76	113	152	192
70	14.8	29	45	64	82	122	164	207
80	15.9	31	48	68	88	130	175	221
90	16.8	33	51	72	93	138	186	235
100	17.7	35	54	76	98	146	196	247
120	19	38	59	84	107	159	215	271
140	21	41	64	90	116	172	232	293
160	22	44	68	96	124	184	248	313
180	24	46	72	102	132	195	263	332
200	25	49	76	108	139	206	277	350
225	27	52	81	114	147	218	294	371
250	28	55	85	121	155	230	310	391
275	29	57	89	126	163	241	325	410
300	31	60	93	132	170	252	340	429
325	32	62	97	137	177	262		
350	33	65	101	143	183	272		
375	34	67	104	148	190	282		
400	35	69	108	153	196	291		
450	38	73	114					
500	40	77	121					
550	42	81	126					
600	43	85	132					

NOTE: Taylor Valve reserves the right to change product designs and specifications without notice.

Series 88/89

Series 88 and 89 are multiple purpose safety valves for air / gas protection. Designed for durability, yet an economical choice for safety and relief applications. Choose for a variety of applications where mid-level capacity is required.

ASME and National Board Certified for Section VIII as well as CRN Certifications.

Usages:

Over pressure protection on Pressure vessels,
Piping systems, Tanks, Compressors, Dryers, Inter and After-coolers.

Features:

- Precision lapped metal to metal seating
- Stainless steel springs
- Ruggedly constructed
- Closed seal hex cap or lift lever options
- Wide variety of inlet and outlet options
- Disk-guided seat provides quick, accurate and excellent re-seating
- Maximum temperature 406°F (208°C)



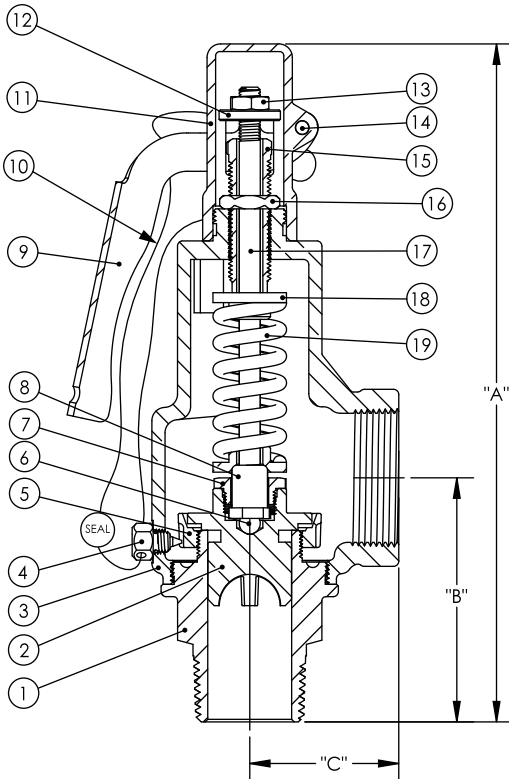

SERIES 88/89 - Bill of Materials

Item	Description	Brass Option	Stainless Option
1	Body	B16/B283	316 Stainless
2	Disc	B62	316 Stainless
3	Bonnet	B584	B584
4	Lock Screw	B16	B16
5	Lower Ring	B584	B584
6	Ball	Stainless	Stainless
7	Disc Nut	B16	B16
8	Spring Support	B16	B16
9	Lift Lever	Plated Steel	Plated Steel
10	Seal Wire	Steel/Lead	Steel/Lead
11	Hood	Aluminum	Aluminum
12	Lifter Nut	B16	B16
13	Jam Nut	B16	B16
14	Lever Pin	B16	B16
15	Pressure Screw	B16	B16
16	Locknut	B16	B16
17	Spring Post	B16	B16
18	Spring Plate	B16	B16
19	Spring	302/17-7	302/17-7
20	Nameplate	Stainless	Stainless
21	Hood	B16	B16
22	Hood Seal	PTFE	PTFE

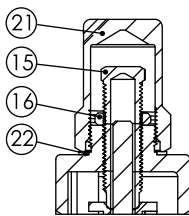

Series 89

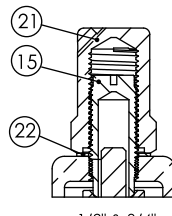

1/2" & 3/4"
Series 89

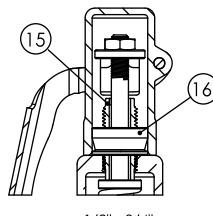

1/2" - 3/4"
Lift Levers

SERIES 88/89 - Dimensions

Size I.D.	Inlet	Outlet	DN	Dimension - In. (mm)				Weight Lb - (Kg)
				A-88	A-89	B	C	
A1	1/2"	1/2"	15	6-7/8" (175)	6" (152)	2-1/2" (64)	1-3/8" (35)	1.7 (0.8)
A1	1/2"	3/4"	15	6-7/8" (175)	6" (152)	2-1/2" (64)	1-3/8" (35)	1.7 (0.8)
B1	3/4"	3/4"	20	7-1/8" (181)	6-1/4" (159)	2-5/8" (67)	1-1/2" (38)	2.2 (1)
B2	3/4"	1"	20	7-1/8" (181)	6-1/4" (159)	2-5/8" (67)	1-1/2" (38)	2.2 (1)
C1	1"	1"	25	7-7/8" (200)	7-3/8" (187)	2-7/8" (73)	1-3/4" (44)	3 (1.4)
C2	1"	1-1/4"	25	7-7/8" (200)	7-3/8" (187)	2-7/8" (73)	1-3/4" (44)	3 (1.4)
D1	1-1/4"	1-1/4"	32	8-3/4" (222)	8-1/4" (210)	3-3/8" (86)	2" (51)	4 (1.8)
D2	1-1/4"	1-1/2"	32	8-3/4" (222)	8-1/4" (210)	3-3/8" (86)	2" (51)	4 (1.8)
E1	1-1/2"	1-1/2"	40	9-7/8" (251)	9-1/2" (241)	3-1/2" (89)	2-1/8" (54)	5.8 (2.6)
E2	1-1/2"	2"	40	9-7/8" (251)	9-1/2" (241)	3-1/2" (89)	2-1/8" (54)	5.8 (2.6)
F1	2"	2"	50	11-1/4" (286)	11" (279)	3-7/8" (98)	2-5/8" (67)	9.7 (4.4)
F2	2"	2-1/2"	50	11-1/4" (286)	11" (279)	3-7/8" (98)	2-5/8" (67)	9.7 (4.4)
G1	2-1/2"	2-1/2"	65	13-7/8" (352)	13" (330)	5-1/4" (133)	3-5/8" (92)	19 (8.6)
G2	2-1/2"	3"	65	13-7/8" (352)	13" (330)	5-1/4" (133)	3-5/8" (92)	19 (8.6)
H1	3"	3"	80	13-7/8" (352)	13-1/4" (337)	5-5/8" (143)	3-5/8" (92)	19 (8.6)

"G" and "H" are Non-Code

SERIES 88 / 89 AIR CAPACITY SCFM - ASME SECTION VIII

Slope	.644	.93	2.274	3.504	4.90	7.404	13.416	16.98
Set PSI	A 1/2"	B 3/4"	C 1"	D 1-1/4"	E 1-1/2"	F 2"	G* 2-1/2"	H* 3"
5	15	21	52	80	111	168	305	385
10	18	26	63	97	136	205	372	470
15	21	30	74	115	160	242	439	555
20	24	35	86	132	185	279	506	640
25	27	40	97	150	209	316	573	725
30	31	44	108	167	234	353	640	810
35	34	49	121	186	261	394	714	903
40	38	55	133	206	288	435	788	997
45	41	60	146	225	315	475	861	1090
50	45	65	158	244	342	516	935	1184
55	48	70	171	264	368	557	1009	1277
60	52	75	184	283	395	598	1083	1370
65	56	80	196	302	422	638	1156	1464
70	59	85	209	321	449	679	1230	1557
75	63	90	221	341	476	720	1304	1650
80	66	96	234	360	503	760	1378	1744
85	70	101	246	379	530	801	1452	1837
90	73	106	259	398	557	842	1525	1931
95	77	111	271	418	584	883	1599	2024
100	80	116	284	437	611	923	1673	2117
120	94	136	334	514	719	1086	1968	2491
140	109	157	384	591	827	1249	2263	2865
160	123	177	434	668	934	1412	2558	3238
180	137	198	484	745	1042	1575	2854	3612
200	151	218	534	822	1150	1738	3149	3985
220	165	239	584	899	1258	1901	3444	4359
240	179	259	634	977	1366	2063	3739	4732
250	187	269	659	1015	1420	2145	3887	4919

Capacities are at 3 PSI or 10% (whichever is greater) over set pressure

* 2-1/2" ("G") and 3" ("H") sizes are NON-Code

Set pressures below 15 PSI (1.03 Bar) are NON-Code.

Maximum back-pressure is 10% of set pressure or 50 PSI (3.45 Bar) whichever is less.

Lifting Device as required by the ASME, ASME Section VIII: UG136(3)

Each pressure relief valve on air, water at the valve inlet that exceeds 140°F (60°C), excluding over-pressure or relief events, or steam service shall have a substantial lifting device which when activated will release the seating force on the disc when the pressure relief valve is subjected to a pressure of at least 75% of the set pressure of the valve.

PTFE SOFT SEAT			
Item	Description	Material	Stainless
1	Handle	B16/B283	316 Stainless
5	Handle Screw	B584	B584
23	Cam	B16	316 Stainless
24	Retaining Ring	Steel/Plated	PTFE
25	O-Rings	Viton	316 Stainless
26	Cam Nut	B16 Brass	B16

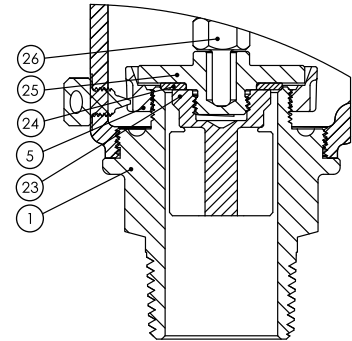

PACKED LIFT LEVER OPTION		
Item	Description	Material
1	Handle	B16 Brass
2	Handle Screw	Steel/Plated
3	Cam	B16 Brass
4	Retaining Ring	Steel/Plated
5	O-Rings	Viton
6	Cam Nut	B16 Brass
7	O-Ring	PTFE
8	Hood	B 16 Brass
9	Jam Nut	18-8 Stainless
10	Lifter Nut	B 16 Brass
11	Hood Seal	PTFE
12	Plug	Gag Screw Option 18-8/PTFE
13	Seal	
14	Gag Screw	

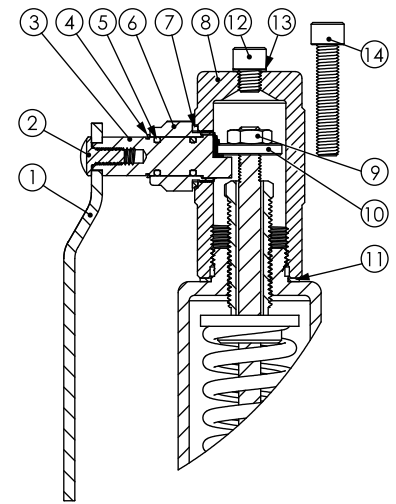

SERIES 88/89 - PART NUMBERS

88	C	2	A	1	M	1	K	1	125
Series	Inlet	Outlet	Metals	Connection	Seating	Cap	Service	Options	Set
88	A - 1/2"	1 - Same Size as Inlet	A - Brass/Bronze	1 - NPT MxF	M - Metal	1 - Lift Lever	K - ASME VIII Air/Gas	1 - None	Ex. 125
89	B - 3/4"					2 - Closed Cap			
	C - 1"	2 - Next Larger than Inlet				3 - Packed lift Lever			
	D - 1-1/4"								
	E - 1-1/2"								
	F - 2"								
	G - 2-1/2"								
	H - 3"								

Series 560/570

Our 560 / 570 valve line is a high capacity safety valve used for boilers, piping lines and vessel protection. Designed and engineered for heavy-duty industrial use. ASME and National Board Certified for Section I and VIII as well as CE and CRN Certifications.

SERIES 560

Use for ASME Section I applications.
Boilers, or most areas where steam safety valves are required.
Set pressure up to 250 PSI (17.2 Bar).

SERIES 570

ASME Section VIII, CE, CRN certified for unfired vessel protection.
Used for many applications to protect or relieve pressure for Air / Gas or Steam.
Set pressures: Air up to 300 PSI (20.7 Bar), Steam to 250 PSI (17.2 Bar).

Usages:

Steam Boilers, Air Compressors, Dryers, Receivers, Pressure Vessels, Piping Systems, Accumulators, Reducing Stations, Tanks, Inter/After Coolers, Cooking Equipment, Autoclaves, Sterilizers or wherever higher capacity pressure protection or relief may be required.

Features:

- Designed for durability
- 6 orifices – 12 sizes of piping options
- Top guided seating and discharge
- Full nozzle, high capacity levels
- Short, tuned blow-down with dual-ring technology
- Heavy duty hood and lever mechanism
- Standard 17-7 stainless steel springs



NOTE: Taylor Valve reserves the right to change product designs and specifications without notice.

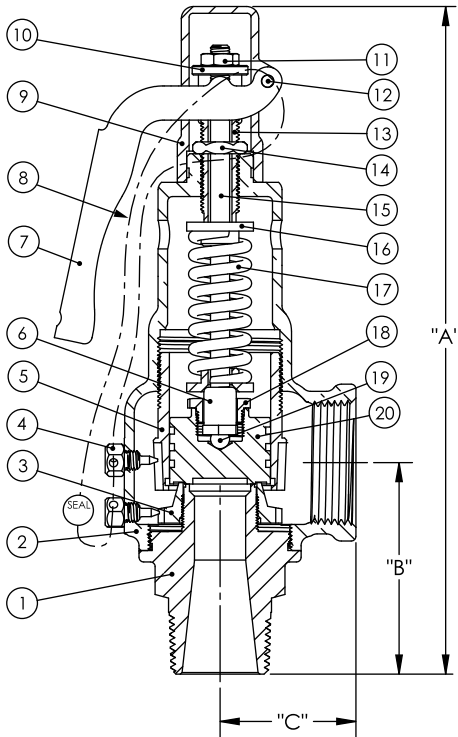

SERIES 560/570 - BOM

Item	Description	560/570
1	Body	B16/B62-C83600
2	Bonnet	B584-C84400
3	Lower Ring	B584-C84400
4	Lock Screw	B16
5	Upper Ring	B584-C84400
6	Spring Support	B16
7	Lift Lever	Steel/Plated
8	Seal Wire	Steel. Galvanized
9	Hood	Aluminum/Plated
10	Lifter Nut	B16
11	Jam Nut	18-8
12	Lever Pin	B16
13	Pressure Screw	B16
14	Locknut	B16
15	Stem	B16
16	Spring Plate	B16
17	Spring	B16
18	Disc nut	B16
19	Ball Bearing	440
20	Disc	B16
21	Name Plate	Stainless

SERIES 560/570 - Dimensions

Orifice	Flow Area in ² (mm ²)	Inlet	Outlet	DN	Size I.D.	Dimension - In. (mm)			Weight Lb - (Kg)
						A	B	C	
D	.125 (80.6)	1/2"	3/4"	15	C	7-1/4" (184)	2-1/2" (64)	1-1/2" (38)	2.5 (1.1)
D	.125 (80.6)	3/4"	3/4"	15	D	7-1/4" (184)	2-1/2" (64)	1-1/2" (38)	2.5 (1.1)
E	.221 (142.6)	3/4"	1"	20	D	7-5/8" (194)	2-1/2" (64)	1-5/8" (41)	3 (1.4)
E	.221 (142.6)	1"	1"	20	E	7-5/8" (194)	2-1/2" (64)	1-5/8" (41)	3 (1.4)
F	.352 (227.1)	1"	1-1/4"	25	E	8-7/8" (225)	2-7/8" (73)	1-3/4" (44)	4 (1.8)
F	.352 (227.1)	1-1/4"	1-1/4"	32	F	8-7/8" (225)	2-7/8" (73)	1-3/4" (44)	4 (1.8)
G	.567 (365.8)	1-1/4"	1-1/2"	32	F	9-1/2" (241)	3-1/4" (83)	2-1/4" (57)	6 (2.7)
G	.567 (365.8)	1-1/2"	1-1/2"	40	G	9-5/8" (244)	3-1/4" (83)	2-1/4" (57)	6 (2.7)
H	.899 (580.0)	1-1/2"	2"	40	G	11" (279)	3-5/8" (92)	2-1/2" (64)	10 (4.5)
H	.899 (580.0)	2"	2"	50	H	11" (279)	3-5/8" (92)	2-1/2" (64)	10 (4.5)
J	1,463 (943.9)	2"	2-1/2"	50	H	12-5/8" (321)	4" (102)	3-1/8" (79)	15 (6.8)
J	1,463 (943.9)	2-1/2"	2-1/2"	65	J	12-5/8" (321)	4" (102)	3-1/8" (79)	15 (6.8)

Series	METALS	MIN. TEMP °F (°C)	MAX. TEMP °F (°C)	MAX PRESSURE PSI (BAR)	SERVICES	CERTIFICATIONS
560	Brass/Bronze	-20° (-29°)	406° (208°)	250 (17.2)	Steam	ASME I, CE, CRN
570	Brass/Bronze	-20° (-29°)	406° (208°)	300 (20.7)	Air/Gas/Steam	ASME VIII, CE, CRN

SERIES 560/570 - PART NUMBERS

560	DC	1	M	1	L	1	250
Series/Description	Orifice/Size ID	Connection	Seating	Cap	Service	Options	Set
560 - Brass/Bronze Section 1	DC - 1/2" x 3/4"	1 - NPT MxF	M - Metal	1 - Lift Lever	L - ASME VIII - Steam	1 - None	Ex. 250
	DD - 3/4" x 3/4"			3 - Packed lift Lever	A - ASME I Steam		
570 - Brass/Bronze Section VIII	DE - 1/2" x 1"						
	DF - 3/4" x 1"						
	ED - 3/4" x 1"						
	EE - 1" x 1"						
	FE - 1" x 1-1/4"						
	FF - 1-1/4" x 1-1/4"						
	GF - 1-1/4" x 1-1/2"						
	GG - 1-1/2" x 1-1/2"						
	HG - 1-1/2" x 2"						
	HH - 2" x 2"						
JH - 2" x 2-1/2"							
JJ - 2-1/2" x 2-1/2"							

SERIES 560 CAPACITIES STEAM KG/HR – ASME SECTION I

SET BAR	ORIFICE AREA mm ² FLOW COEFFICIENT = .856					
	"D" 80.6	"E" 142.6	"F" 227.1	"G" 365.8	"H" 580.0	"J" 943.9
0.2	49	87	138	222	352	573
0.5	60	106	169	272	431	701
1	78	138	220	354	561	913
2	114	202	322	518	822	1337
3	150	266	424	683	1082	1761
4	187	330	526	847	1343	2185
5	223	395	629	1013	1607	2615
6	261	461	734	1183	1875	3052
7	298	527	839	1352	2144	3489
8	335	593	944	1521	2412	3926
9	373	659	1050	1691	2681	4362
10	410	725	1155	1860	2949	4799
11	447	791	1260	2029	3218	5236
12	484	857	1365	2199	3486	5673
13	522	923	1470	2368	3755	6110
14	559	989	1575	2537	4023	6547
15	596	1055	1680	2707	4292	6984
16	634	1121	1785	2876	4560	7421
17	671	1187	1891	3045	4829	7858
18	708	1253	1996	3215	5097	8295
19	746	1319	2101	3384	5365	8732
20	783	1385	2206	3553	5634	9169
20.7	809	1431	2280	3672	5822	9475

Capacities are at 2 PSI or 3% (whichever is greater) over set pressure

Set pressures below 15 PSI (1.03 Bar) are NON-Code.

Section I Lift levers can not be omitted.

Lifting Device as required by the ASME:

ASME Section I - PG-73.2.4

Each safety valve shall have a substantial lifting device, which when activated will release the seating force on the disc when the valve is subjected to a pressure of at least 75% of the set pressure.

SERIES 570 CAPACITIES STEAM LBS/HR – ASME SECTION VIII

SET PSI	ORIFICE AREA in ² FLOW COEFFICIENT = .856					
	“D” .125	“E” .221	“F” .352	“G” .567	“H” .899	“J” 1.463
5	125	221	352	567	900	1464
10	153	270	430	692	1098	1787
15	180	319	507	817	1296	2109
20	208	367	585	942	1494	2431
25	235	416	663	1067	1692	2754
30	263	465	740	1192	1890	3076
35	293	518	826	1330	2108	3431
40	323	572	911	1467	2326	3786
45	354	625	996	1605	2544	4141
50	384	679	1082	1742	2762	4495
55	414	733	1167	1880	2980	4850
60	445	786	1252	2017	3198	5305
65	475	840	1338	2155	3416	5559
70	505	893	1423	2292	3634	5914
75	536	947	1508	2430	3852	6269
80	566	1001	1594	2567	4070	6624
85	596	1054	1679	2705	4288	6978
90	627	1108	1764	2842	4506	7333
95	657	1161	1850	2979	4724	7688
100	687	1215	1935	3117	4942	8043
110	748	1322	2106	3392	5378	8752
120	808	1429	2276	3667	5814	9461
130	869	1536	2447	3942	6250	10171
140	930	1644	2618	4217	6686	10880
150	990	1751	2789	4492	7122	11590
160	1051	1858	2959	4767	7558	12299
170	1111	1965	3130	5042	7994	13009
180	1172	2072	3301	5317	8430	13718
190	1233	2179	3471	5592	8866	14428
200	1293	2287	3642	5866	9303	15137
210	1354	2394	3813	6141	9737	15846
220	1415	2501	3983	6416	10173	16556
230	1475	2608	4154	6691	10609	17265
240	1536	2715	4325	6966	11045	17975
250	1596	2822	4495	7241	11481	18684
270	1718	3037	4837	7791	12353	20103
290	1839	3251	5178	8341	13225	21522
300	1899	3358	5349	8616	13661	22231

Capacities are at 3 PSI or 10% (whichever is greater) over set pressure

Set pressures below 15 PSI (1.03 Bar) are NON-Code.

Lifting Device as required by the ASME, Section VIII: UG136(3) Each pressure relief valve on air, water at the valve inlet that exceeds 140°F (60°C), excluding over-pressure or relief events, or steam service shall have a substantial lifting device which when activated will release the seating force on the disc when the pressure relief valve is subjected to a pressure of at least 75% of the set pressure of the valve.



Taylor Valve Technology
8300 S.W. 8th Street
Oklahoma City, Oklahoma 73128

TEL 405.787.0145
FAX 800.805.3401
WEB www.taylorvalve.com
EMAIL info@taylorvalve.com



Precise.

Quality.

Reliable.