

TRUSTED  
**SINCE 1958**  
WORLDWIDE

*The  
Original  
Self-Aligning  
Technology®*

Precise.

Quality.

Reliable.

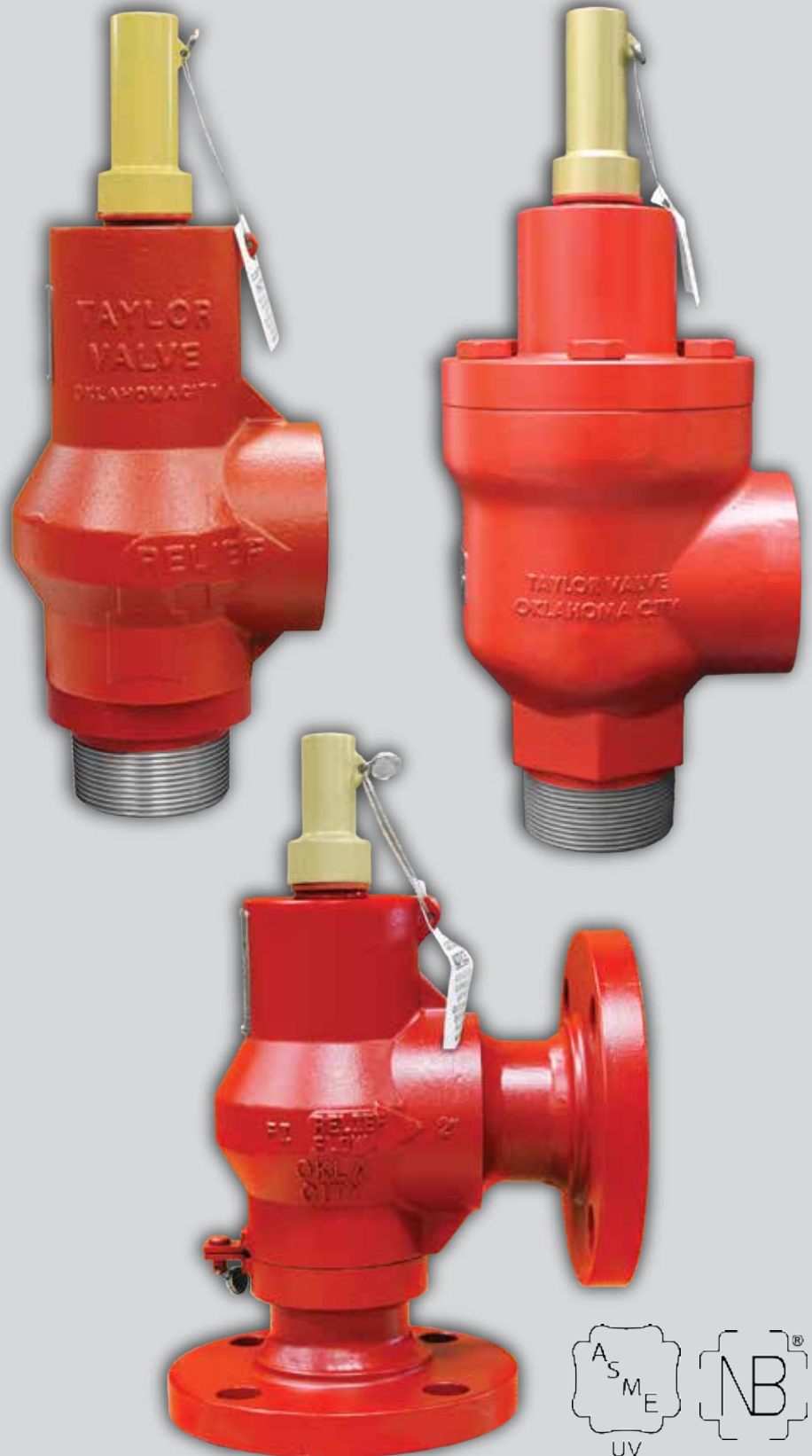

## 8250 THREADED & FLANGED VALVES

The Taylor 8250 Safety Relief Valve is manufactured in accordance with the requirements of ASME Boiler and Pressure Vessel Code, Section XIII, Division 1 for Air/Gas and Liquid service.

This makes the 8250 an excellent choice for Air, Gas or Liquid relief applications, including Compressors, Separators, Heater Treaters, Free Water Knockouts, Scrubbers, Dehydrators, Thermal Relief, Gas Production Units, Transmission and Gathering Lines, Chemical Plants, Refineries, Meter Runs, Gas Plants and other Industrial Applications.



Taylor Valve is proud to announce the release of the 8250 Series Relief valve.

Features of the 8250 below:

- ◆ Designed with the original Self-Aligning technology.
- ◆ **C** orifice with pressure to 10,000 psi
- ◆ **L** orifice in 3 x 4 and 4 x 6 flanged connections
- ◆ **M** orifice in a 4 x 6 flanged connection
- ◆ Increased capacity in all orifices
- ◆ Top entry style valve **H** orifice and larger
- ◆ API connections available in most flanged connections
- ◆ All orifices are ASME certified by the National Board of Boiler and Pressure Vessels in accordance to Sec XIII Div I. for air/gas and liquid service.

The 8250 redesign is just the beginning of new things to come from Taylor Valve, the Original Self-Aligning Technology® company. Self-Aligning technology allows for repeatable uses without resetting or repair.

# Table of Contents

## Specifications

1" 8250 Valve .....	4
2" 8250 Valve .....	5-6
3" & 4" 8250 Valves.....	7

## Material Overview

Bill of Materials .....	8-10
Flow Capacity.....	11-13

## Ordering

Part Numbering system.....	14-15
----------------------------	-------

## 1" THREADED CONNECTIONS

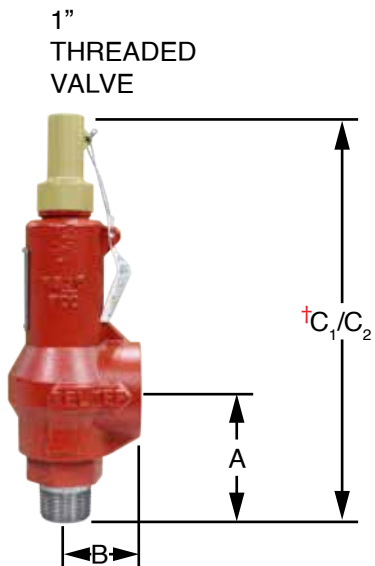

ORIFICE	INLET	OUTLET	DIMENSIONS (in)			
			A	B	C <sub>1</sub>	C <sub>2</sub>
C, D	1/2" MNPT	1" FNPT	3-1/2	1-7/8	10-3/8	11-11/16
	1/2" FNPT		3-1/4	1-7/8	10-1/8	11-7/16
	1/2" MNPT	1-1/2" FNPT	3-1/2	1-7/8	10-3/8	11-11/16
	1/2" FNPT		3-1/4	1-7/8	10-1/8	11-7/16
D	1/2" MNPT	3/4" FNPT	3-1/2	1-7/8	10-3/8	11-11/16
	1/2" FNPT		3-1/4	1-7/8	10-1/8	11-7/16
	3/4" MNPT		3-1/4	1-7/8	10-1/8	11-7/16
	3/4" FNPT		3-1/8	1-7/8	10	11-5/16
C, D, E	3/4" MNPT	1" FNPT	3-1/4	1-7/8	10-1/8	11-7/16
	3/4" FNPT		3-1/8	1-7/8	10	11-5/16
	1" MNPT		3-1/4	1-7/8	10-1/8	11-7/16
	1" FNPT		3-1/8	1-7/8	10	11-5/16
	3/4" MNPT	1-1/2" FNPT	3-1/4	1-7/8	10-1/8	11-7/16
	3/4" FNPT		3-1/8	1-7/8	10	11-5/16
	1" MNPT		3-1/4	1-7/8	10-1/8	11-7/16
	1" FNPT		3-1/8	1-7/8	10	11-5/16

†The "C" that corresponds to a particular valve's overall dimension is based on set point and orifice size.

ORIFICE	SET PRESSURE RANGE (psi)	
	C <sub>1</sub>	C <sub>2</sub>
C	300-6000	6001-10000
D	15-2800	2801-5000
E	15-1500	1501-3000

## 1" FLANGED CONNECTIONS

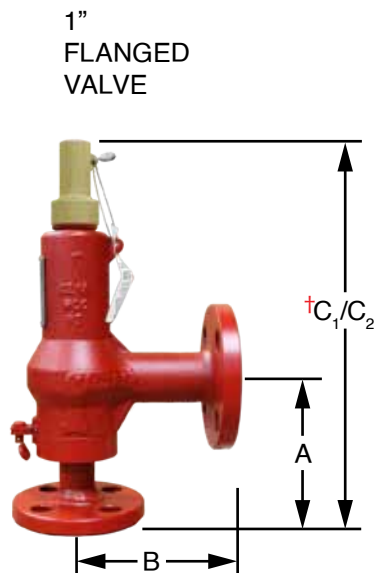

ORIFICE	INLET X OUTLET (inches)	FLANGE CLASSES INLET x OUTLET	DIMENSIONS (in)			
			A	B	C <sub>1</sub>	C <sub>2</sub>
C, D, E	3/4 x 1	150 x 150	4-1/8	4-1/2	11	-
		300 x 150	4-1/8	4-1/2	11	-
		600 x 150	4-1/8	4-1/2	11	-
		900/1500 x 300	4-1/8	4-1/2	11	12-5/16
	1 x 1	150 x 150	4-1/8	4-1/2	11	-
		300 x 150	4-1/8	4-1/2	11	-
		600 x 150	4-1/8	4-1/2	11	-
		900/1500 x 300	4-1/2	4-1/2	11-3/8	12-11/16
	1 x 1-1/2	150 x 150	4-1/8	4-3/4	11	-
		300 x 150	4-1/8	4-3/4	11	-
		600 x 150	4-1/8	4-3/4	11	-
		900/1500 x 300	4-1/2	4-3/4	11-3/8	12-11/16
1 x 2	150 x 150*	4-1/8	4-1/2	11	-	
	300 x 150*	4-1/8	4-1/2	11	-	
	600 x 150*	4-1/8	4-1/2	11	-	
	900/1500 x 300	4-1/2	4-1/2	11-3/8	12-11/16	
D, E	1-1/2 x 2	150 x 150	4-7/8	4-3/4	11-3/4	-
		300 x 150	4-7/8	4-3/4	11-3/4	-
		600 x 150	4-7/8	5-1/2	11-3/4	-
		900/1500 x 300*	4-1/8	5-1/2	11	12-5/16

\* Denotes dimensions in accordance to API 526

## 2" THREADED CONNECTIONS

ORIFICE	INLET	OUTLET	DIMENSIONS (in)			
			A	B	C <sub>1</sub>	C <sub>2</sub>
F	1" MNPT	2" FNPT	4-1/4	2-5/16	10-1/2	13-7/8
	1" FNPT		4-1/4	2-5/16	10-1/2	13-7/8
F, G	1-1/2" MNPT	2" FNPT	4-1/4	2-5/16	10-1/2	13-7/8
	1-1/2" FNPT		4-1/4	2-5/16	10-1/2	13-7/8
	2" MNPT		4-1/4	2-5/16	10-1/2	13-7/8
	2" FNPT		4-1/4	2-5/16	10-1/2	13-7/8

2" THREADED VALVE

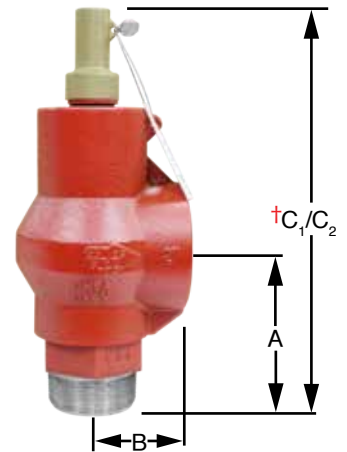

†The "C" that corresponds to a particular valve's overall dimension is based on set point and orifice size.

Use NACE settings marked in parenthesis if different than standard.

ORIFICE	SET PRESSURE RANGE (psi)	
	C <sub>1</sub>	C <sub>2</sub>
F	15-1500	1501-3000
G (NACE)	15-800 (15-725)	801-2000 (726-2000)

## 2" FLANGED CONNECTIONS

ORIFICE	INLET X OUTLET (inches)	FLANGE CLASSES INLET x OUTLET	DIMENSIONS (in)			
			A	B	C <sub>1</sub>	C <sub>2</sub>
F, G	1-1/2 x 2	150 x 150*	4-7/8	4-3/4	11-1/8	-
		300 x 150*	4-7/8	4-3/4	11-1/8	14-1/2
		600 x 150*	4-7/8	6	11-1/8	14-1/2
		900/1500 x 300	4-7/8	6-3/8	11-1/8	14-1/2
	1-1/2 x 3	150 x 150*	4-7/8	4-3/4	11-1/8	-
		300 x 150*	4-7/8	4-3/4	11-1/8	14-1/2
		600 x 150*	4-7/8	6	11-1/8	14-1/2
		900/1500 x 300*	4-7/8	6-1/2	11-1/8	14-1/2
	2 x 2	150 x 150	5-1/8	4-3/4	11-3/8	-
		300 x 150	5-1/8	4-3/4	11-3/8	14-3/4
		600 x 150	5-1/8	6	11-3/8	14-3/4
		900/1500 x 300	6-1/8	6-3/8	12-3/8	15-3/4
	2 x 2-1/2	150 x 150	5-1/8	4-7/8	11-3/8	-
		300 x 150	5-1/8	6	11-3/8	14-3/4
		600 x 150	5-1/8	6	11-3/8	14-3/4
		900/1500 x 300	6-1/8	6-3/8	12-3/8	15-3/4
2 x 3	150 x 150	5-1/8	4-3/4	11-3/8	-	
	300 x 150	5-1/8	6	11-3/8	14-3/4	
	600 x 150	5-1/8	6	11-3/8	14-3/4	
	900/1500 x 300*	6-1/8	6-3/4	12-3/8	15-3/4	

2" FLANGED VALVE

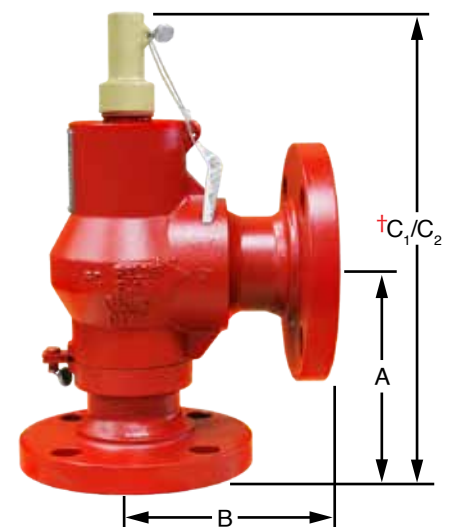

\* Denotes dimensions in accordance to API 526

NOTE: Taylor Valve reserves the right to change product designs and specifications without notice.

## 2" THREADED CONNECTIONS

TOP ENTRY  
DIMENSIONS (in)

ORIFICE	INLET	OUTLET	TOP ENTRY DIMENSIONS (in)			
			A	B	C <sub>1</sub>	C <sub>2</sub>
H ^	1-1/2" MNPT	2" FNPT	4-1/4	3	14-9/16	16-15/16
	1-1/2" FNPT		3-1/2	3	13-13/16	16-3/16
	2" MNPT		4-1/4	3	14-9/16	16-15/16
	2" FNPT		3-1/2	3	13-13/16	16-3/16
	1-1/2" MNPT	2-1/2" FNPT	4-1/4	3	14-9/16	16-15/16
	1-1/2" FNPT		3-1/2	3	13-13/16	16-3/16
	2" MNPT		4-1/4	3	14-9/16	16-15/16
	2" FNPT		3-1/2	3	13-13/16	16-3/16

^ Denotes top entry style valve

2" THREADED "H" VALVE

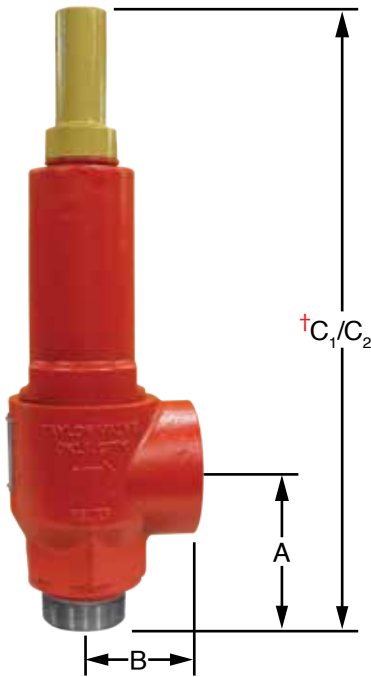

† The "C" that corresponds to a particular valve's overall dimension is based on set point and orifice size.

Use NACE settings marked in parenthesis if different than standard.

ORIFICE	SET PRESSURE RANGE (psi)	
	C <sub>1</sub>	C <sub>2</sub>
H (NACE)	15-320 (15-350)	321-1600 (351-1500)

## 2" FLANGED CONNECTIONS

DIMENSIONS (in)

ORIFICE	INLET X OUTLET (inches)	FLANGE CLASSES INLET x OUTLET	DIMENSIONS (in)			
			A	B	C <sub>1</sub>	C <sub>2</sub>
H ^	1-1/2 x 2	150 x 150	5-1/8	4-7/8	15-7/16	-
		300 x 150	5-1/8	4-7/8	15-7/16	17-13/16
		600 x 150	4-7/8	4-7/8	15-3/16	17-9/16
		1500 x 300	4-7/8	6 3/8	15-3/16	17-9/16
	1-1/2 x 3	150 x 150*	5-1/8	4-7/8	15-7/16	-
		300 x 150*	5-1/8	4-7/8	15-7/16	17-13/16
		600 x 150	4-7/8	6-3/8	15-3/16	17-9/16
		1500 x 300	4-7/8	6-3/8	15-3/16	17-9/16
	2 x 2	150 x 150	5-1/8	4-7/8	15-7/16	-
		300 x 150	5-1/8	4-7/8	15-7/16	17-13/16
		600 x 150	6-1/16	6	16-3/8	18-3/4
		1500 x 300	6-1/16	6	16-3/8	18-3/4
	2 x 2-1/2	150 x 150	5-1/8	4-7/8	15-7/16	-
		300 x 150	5-1/8	6	15-7/16	17-13/16
		600 x 150	6-1/16	6	16-3/8	18-3/4
		1500 x 300	6-1/16	6	16-3/8	18-3/4
	2 x 3	150 x 150	5-1/8	4-7/8	15-7/16	-
		300 x 150*	5-1/8	4-7/8	15-7/16	17-13/16
		600 x 150*	6-1/16	6-3/8	16-3/8	18-3/4
		1500 x 300*	6-1/16	6-3/8	16-3/8	18-3/4

^ Denotes top entry style valve

\* Denotes dimensions in accordance to API 526

## 3" THREADED CONNECTIONS

ORIFICE	INLET	OUTLET	DIMENSIONS (in)			
			A	B	C <sub>1</sub>	C <sub>2</sub>
J	2" MNPT	3" FNPT	5-15/16	3-5/8	16-13/16	-
	2" FNPT		5-15/16	3-5/8	16-13/16	-
	2-1/2" MNPT		5-15/16	3-5/8	16-13/16	-
	3" MNPT		5-15/16	3-5/8	16-13/16	-
	3" FNPT		5-15/16	3-5/8	16-13/16	-
J <sup>^</sup>	2" MNPT	3" FNPT	5-15/16	4-1/4	-	18.5
	2" FNPT		5-15/16	4-1/4	-	18.5
J <sup>^</sup> , K <sup>^</sup>	2-1/2" MNPT	3" FNPT	5-15/16	4-1/4	17(K)	18.5
	3" MNPT		5-15/16	4-1/4	17(K)	18.5

† The "C" that corresponds to a particular valve's overall dimension is based on set point and orifice size.

Use NACE settings marked in parenthesis if different than standard.

ORIFICE	SET PRESSURE RANGE (psi)		
	C <sub>1</sub>	C <sub>2</sub>	C <sub>3</sub>
J (NACE)	15-540 (15-375)	541-1000 (376-1000)	1001-1800 (N/A)
K (NACE)	15-300 (15-250)	301-650 (251-650)	651-1500 (N/A)
L (NACE)	15-100	101-450	451-1250 (451-800)
M (NACE)	15-85 (15-80)	86-360 (81-360)	361-1000 (361-700)

## 3" & 4" FLANGED CONNECTIONS

ORIFICE	INLET X OUTLET (inches)	FLANGE CLASSES INLET x OUTLET	DIMENSIONS (in)				
			A	B	C <sub>1</sub>	C <sub>2</sub>	C <sub>3</sub>
J	2 x 3	150 x 150	5-3/8	5-7/8	16-1/4	-	-
		300 x 150	5-3/8	5-7/8	16-1/4	-	-
		600 x 150	6-7/8	6-3/4	17-3/4	-	-
	2-1/2 x 3	150 x 150	6-1/16	5-7/8	16-15/16	-	-
		300 x 150	6-1/16	5-7/8	16-15/16	-	-
		600 x 150	6-3/8	6-3/8	17-1/4	-	-
	3 x 3	150 x 150	6-1/8	6-3/8	17	-	-
		300 x 150	6-1/8	6-3/8	17	-	-
		600 x 150	7-1/8	6-3/4	18	-	-
	3 x 4 <sup>^</sup>	150 x 150	6-1/8	6-3/8	17-3/4	-	-
		300 x 150*	7-1/4	7-1/8	18-7/8	20-1/4	-
		600 x 150*	7-1/4	7-1/8	18-7/8	20-1/4	23-3/4
900 x 150*		7-1/4	7-1/8	18-7/8	20-1/4	23-3/4	
K	3 x 4 <sup>^</sup>	150 x 150*	6-1/8	6-3/8	17-3/4	19-1/8	-
		300 x 150*	6-1/8	6-3/8	17-3/4	19-1/8	22-5/8
		600 x 150*	7-1/4	7-1/8	18-7/8	20-1/4	23-3/4
		900 x 150	7-1/4	7-1/8	18-7/8	20-1/4	23-3/4
L	3 x 4 <sup>^</sup>	150 x 150*	6-1/8	6-1/2	19-1/8	22-13/16	-
		300 x 150*	6-1/8	6-1/2	19-1/8	22-13/16	-
	4 x 6 <sup>^</sup>	300 x 150*	7-1/16	7-1/8	20	23-11/16	30-1/4
		600 x 150*	7-1/16	8	20	23-11/16	30-1/4
M	4 x 6 <sup>^</sup>	150 x 150*	7	7-1/4	19-15/16	23-5/8	-
		300 x 150*	7	7-1/4	19-15/16	23-5/8	30-3/16
		600 x 150*	7	8	19-15/16	23-5/8	30-3/16

<sup>^</sup> Denotes top entry style valve

\* Denotes dimensions in accordance to API 526

3" THREADED VALVE

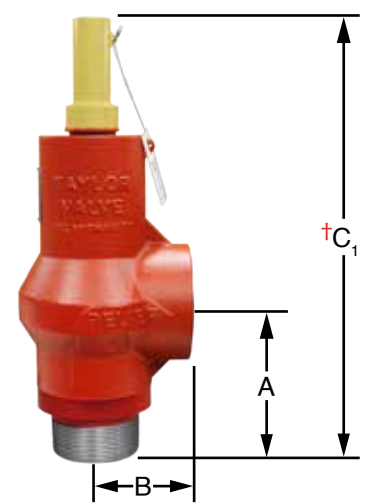

3" TOP ENTRY THREADED VALVE

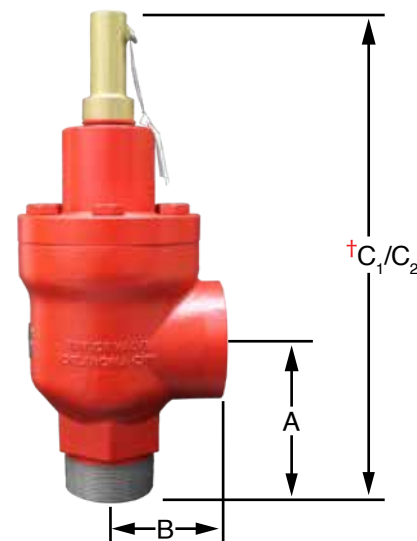

3" FLANGED VALVE

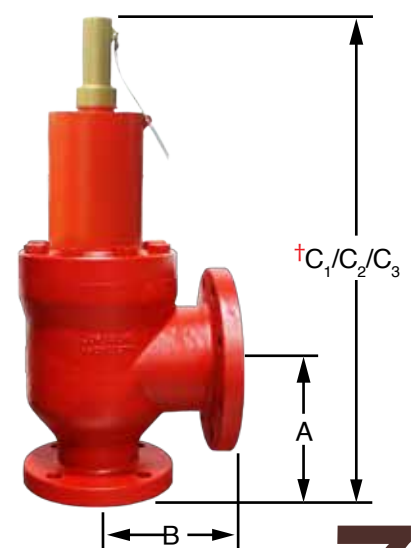

## 1" & 2" BILL OF MATERIALS FOR C-G ORIFICES

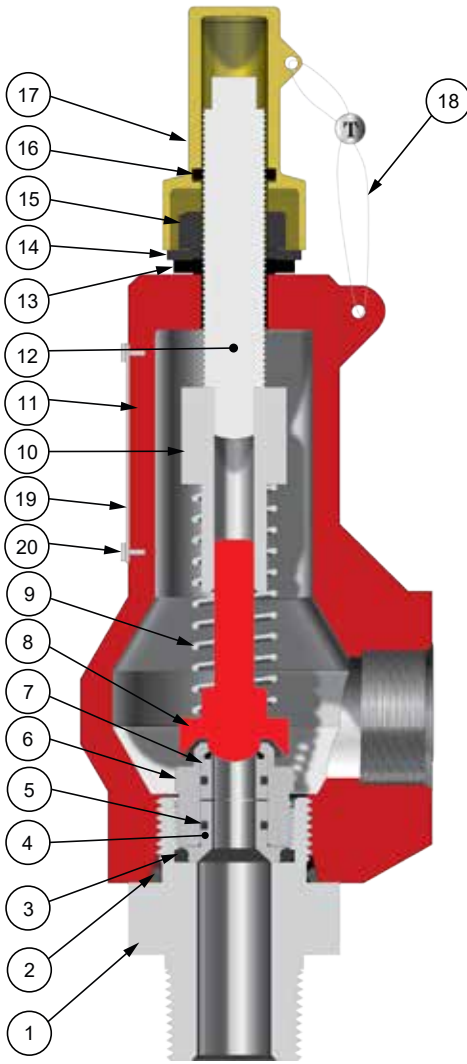

ITEM NO	PART	STANDARD CLOSED TOP CONFIGURATION			
		STANDARD APPLICATION		NACE APPLICATION	
		CARBON STEEL	STAINLESS STEEL	CARBON STEEL	STAINLESS STEEL
1	Seat Frame	SA36 CS	316SS SA479	SA36 CS	316SS SA479
2	O-Ring	Specify	Specify	Specify	Specify
3	O-Ring	Specify	Specify	Specify	Specify
4	Insert Holder	304SS SA479	304SS SA479	304SS/316SS SA479	304SS/316SS SA479
5	O-Ring	Specify	Specify	Specify	Specify
6	Seat Body	17-4SS SA564	17-4SS SA564	316SS SA479/ 17-4H1150M SA564	316SS SA479/ 17-4H1150M SA564
7	Seat Insert	Specify	Specify	Specify	Specify
8 <sup>1</sup>	Disc	17-4SS SA564	17-4SS SA564	316SS SA479/ 17-4H1150M SA564	316SS SA479/ 17-4H1150M SA564
9	Spring	17-7SS SA564	17-7SS SA564	Consult Factory*	Consult Factory*
10	Spring Keeper	304SS SA479	304SS SA479	304SS SA479	304SS SA479
11	Body	SA216 GR WCC	SA351 CF8M	SA216 GR WCC	SA351 CF8M
12 <sup>1</sup>	Adjustment Screw	1018/1020CS A108	304SS SA479	304SS SA479	304SS SA479
13	Thread Seal	Buna/Steel	Buna/Steel	Buna/Steel	Buna/Steel
14	Flat Washer	CS ANSI B18.22.1	18-8SS	CS ANSI B18.22.1	18-8SS
15	Jam Nut	CS ANSI B18.22.1	18-8SS	CS ANSI B18.22.1	18-8SS
16 <sup>1</sup>	O-Ring	PC BUNA	PC BUNA	PC BUNA	PC BUNA
17 <sup>1</sup>	Cap	CS/ZINC	SS	CS/ZINC	SS
18	Lead Seal Wire	SS	SS	SS	SS
19	Data Label	SS	SS	SS	SS
20	Drive Screws	18-8 SS	18-8 SS	18-8 SS	18-8 SS

\* Nace springs- 316SS, MP35N, ELGILOY, OR INCONNEL  
<sup>1</sup> These parts are replaced with Lift Lever option.

1/4" FNPT TAP  
ON SEAT FRAME OPTION

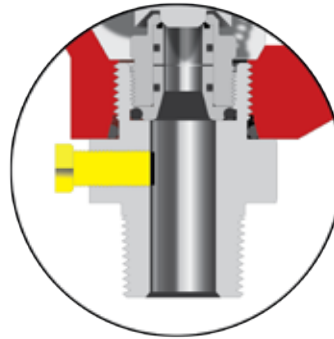

LIFT LEVER OPTION

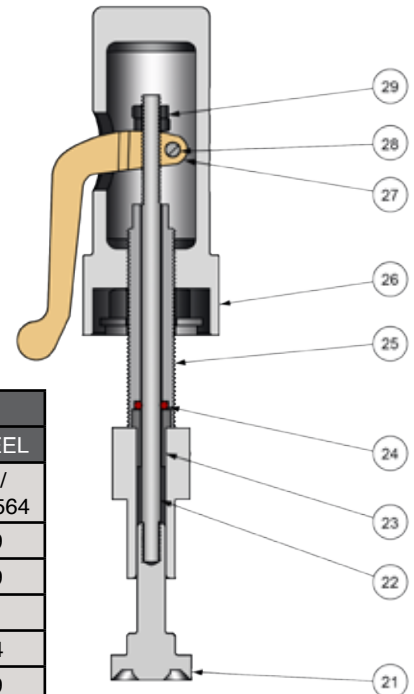

## Relief Valve Options

### LIFT LEVER OPTION BILL OF MATERIALS

ITEM	PART	STANDARD APPLICATION		NACE APPLICATION	
		CARBON STEEL	STAINLESS STEEL	CARBON STEEL	STAINLESS STEEL
21	LL Disc	17-4SS SA564	17-4SS SA564	316SS SA479 / 17-4H1150M SA564	316SS SA479 / 17-4H1150M SA564
22	Stem Extension	304 SS SA479	304 SS SA479	304 SS SA479	304 SS SA479
23	O-Ring Follower	304 SS SA479	304 SS SA479	304 SS SA479	304 SS SA479
24	O-Ring	Specify	Specify	Specify	Specify
25	Adjustment Screw	17-4SS SA564	17-4SS SA564	17-4SS SA564	17-4SS SA564
26	Lift Lever Cap	304 SS SA479	304 SS SA479	304 SS SA479	304 SS SA479
27	Lift Handle	Aluminum Bronze	Aluminum Bronze	Aluminum Bronze	Aluminum Bronze
28	Clevis Pin	316 SS SA479	316 SS SA479	316 SS SA479	316 SS SA479
29	Lock Nut	Steel	Steel	Steel	Steel



### Repair Kits

All repair kits come with o-rings, thread seal, insert holder, seat holder, disc and seat insert.

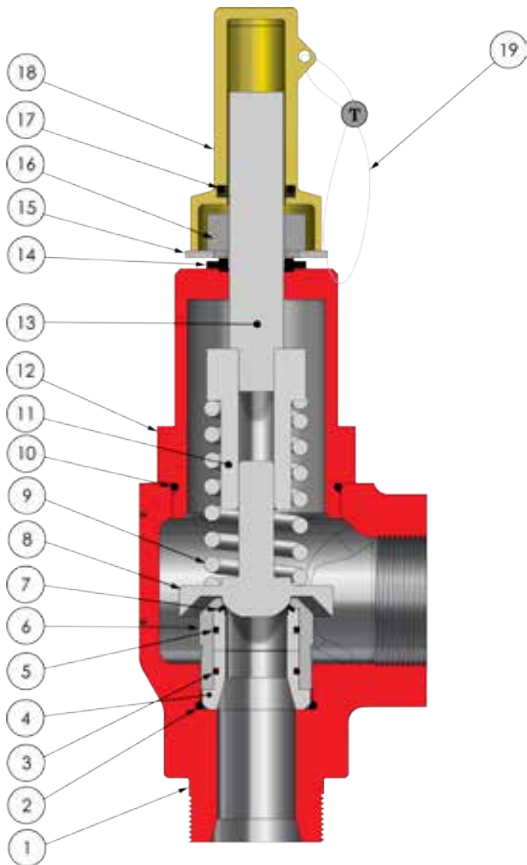

## 2" BILL OF MATERIALS H ORIFICE Top Entry Styles

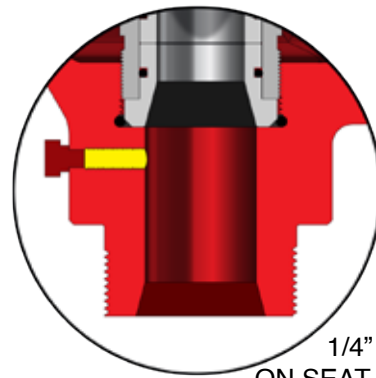

1/4" FNPT TAP  
ON SEAT FRAME OPTION

ITEM	PART	STANDARD CLOSED TOP CONFIGURATION			
		STANDARD APPLICATIONS		NACE APPLICATIONS	
		CARBON STEEL	STAINLESS STEEL	CARBON STEEL	STAINLESS STEEL
1	Body	SA216 GR WCC	SA351 CF8M	SA216 GR WCC	SA351 CF8M
2	O-ring	Specify	Specify	Specify	Specify
3	O-ring	Specify	Specify	Specify	Specify
4	Insert Holder	304 SS SA479	304 SS SA479	304SS/316SS SA479	304SS/316SS SA479
5	O-ring	Specify	Specify	Specify	Specify
6	Seat Body	17-4SS SA564	17-4SS SA564	316SS SA479 / 17-4H1150M SA564	316SS SA479 / 17-4H1150M SA564
7	Seat Insert	Specify	Specify	Specify	Specify
8	Disc	17-4SS SA564	17-4SS SA564	316SS SA479 / 17-4H1150M SA564	316SS SA479 / 17-4H1150M SA564
9	Spring	17-7SS SA564	17-7 PH SS SA564	Consult Factory*	Consult Factory*
10	O-ring	Specify	Specify	Specify	Specify
11	Spring Keeper	304SS SA479	304 SS SA479	304 SS SA479	304 SS SA479
12	Bonnet	CS SA105	316SS SA479	CS SA105	316SS SA479
13	Adjustment Screw	1018/1020CS A108	304 SS SA479	304 SS SA479	304 SS SA479
14	Thread Seal	Buna/Steel	Buna/Steel	Buna/Steel	Buna/Steel
15	Flat Washer	CS ANSI B18.22.1	18-8SS	CS ANSI B18.22.1	18-8SS
16	Jam Nut	CS ANSI B18.22.1	18-8SS	CS ANSI B18.22.2	18-8SS
17	O-ring	PC BUNA	PC BUNA	PC BUNA	PC BUNA
18	Cap	CS/ZINC	SS/CF3M	CS/ZINC	SS/CF3M
19	Lead Seal Wire	SS	SS	SS	SS
20 <sup>1</sup>	Data Label	SS	SS	SS	SS
21 <sup>1</sup>	Drive Screws	18-8 SS	18-8 SS	18-8 SS	18-8 SS

\* Nace springs- 316SS, MP35N, ELGILOY, OR INCONNEL

<sup>1</sup> These parts are not shown

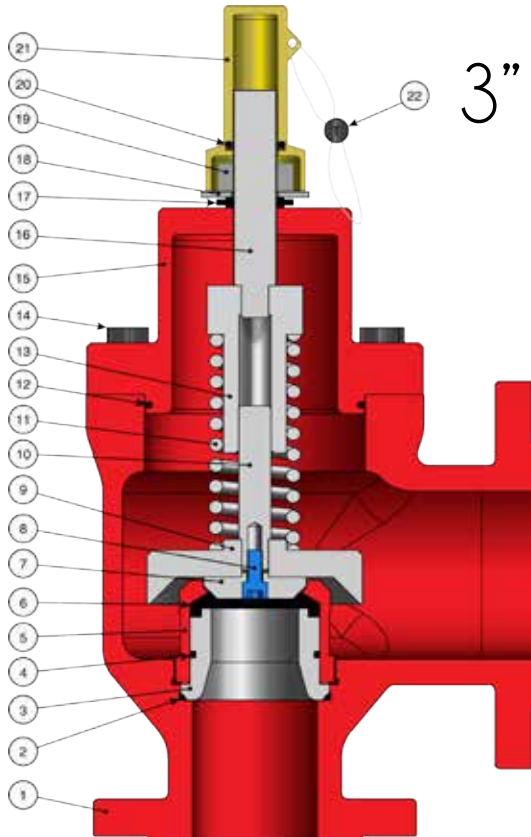

## 3" & 4" BILL OF MATERIALS FOR **J-M** ORIFICES Top Entry Styles

STANDARD CLOSED TOP CONFIGURATION					
ITEM	PART	STANDARD APPLICATION		NACE APPLICATION	
		CARBON STEEL	STAINLESS STEEL	CARBON STEEL	STAINLESS STEEL
1	Body	SA216 GR WCC	SA351 CF8M	SA216 GR WCC	SA351 CF8M
2	O-ring	Specify	Specify	Specify	Specify
3	Insert Holder	304 SS SA479	304 SS SA479	304SS/316SS SA479	304SS/316SS SA479
4	O-ring	Specify	Specify	Specify	Specify
5	Seat Body	17-4SS SA564	17-4SS SA564	316SS SA479 / 17-4H1150M SA564	316SS SA479 / 17-4H1150M SA564
6	Seat Insert	Specify	Specify	Specify	Specify
7	Disc Ball	17-4SS SA564	17-4SS SA564	316SS SA479 / 17-4H1150M SA564	316SS SA479 / 17-4H1150M SA564
8	Disc Screw	B8M SA193	B8M SA193	B8M SA193	B8M SA193
9	Disc Skirt	304 SS SA479	304 SS SA479	304SS/316SS SA479	304SS/316SS SA479
10	Disc Stem	17-4SS SA564	17-4SS SA564	316SS SA479 / 17-4H1150M SA564	316SS SA479 / 17-4H1150M SA564
11	Spring	17-7SS SA564	17-7 PH SS SA564	Consult Factory*	Consult Factory*
12	O-ring	Specify	Specify	Specify	Specify
13	Spring Keeper	304SS SA479	304 SS SA479	304 SS SA479	304 SS SA479
14	Bonnet Bolts	B7 SA193B8	SA193B7	SA193B8	SA193
15	Bonnet	CS SA105	316 SS SA479	CS SA105	316 SS SA479
16	Adjustment Screw	1018/1020CS A108	304 SS SA479	304 SS SA479	304 SS SA479
17	Thread Seal	Buna/Steel	Buna/Steel	Buna/Steel	Buna/Steel
18	Flat Washer	CS ANSI B18.22.1	18-8SS	CS ANSI B18.22.1	18-8SS
19	Jam Nut	CS ANSI B18.22.1	18-8SS	CS ANSI B18.2.2	18-8SS
20	O-ring	PC BUNA	PC BUNA	PC BUNA	PC BUNA
21	Cap	CS/ZINC	SS/CF3M	CS/ZINC	SS/CF3M
22	Lead Seal Wire	SS	SS	SS	SS
23 <sup>1</sup>	Data Label	SS	SS	SS	SS
24 <sup>1</sup>	Drive Screws	18-8 SS	18-8 SS	18-8 SS	18-8 SS

\* Nace springs- 316SS, MP35N, ELGILOY, OR INCONNEL

<sup>1</sup> These parts are not shown

NOTE: Taylor Valve reserves the right to change product designs and specifications without notice.

## Flow Capacity

### WHERE:

- V = Volumetric Flow Rate, SCFM
- W = Mass Flowrate, lb/hr
- Q = Volumetric Flow Rate, GPM
- C = constant for Gas or Vapor based on ratio of specific heats, k (Cp/Cv)
- A = orifice throat area, square inches
- K<sub>d</sub> = Rated Coefficient of Discharge
- M = molecular weight
- P<sub>1</sub> = (stamped set pressure + 3 psi or 10%, whichever is greater) + 14.7 psia
- P<sub>d</sub> = pressure at the discharge of the valve, psia
- T = absolute temperature at inlet, °R (degrees Fahrenheit + 460)
- slope = value determined by the ASME through testing at the National Board Test Lab, Columbus, OH; for Air and Gas service, SCFM/psia
- F = value determined by the ASME through testing at the National Board Test Lab, Columbus, OH; for Liquid service, GPM/ sqrt(PSID)
- G = Specific Gravity
- Z = compressibility factor for gas or vapor, (=1 if unknown)
- K<sub>v</sub> = Viscosity Correction Factor calculated from Reynold's Number and Viscosity (=1 if unknown)

### FLOW CAPACITY CHARTS & FORMULAS

To determine the relieving capacity which should appear on a valve for a given pressure, use either the Coefficient Method or Slope Method.

#### COEFFICIENT METHOD

$$\text{For Gas/Vapor, lb/hr: } W = A C K_d P_1 \sqrt{\frac{M}{T}}$$

$$\text{For Gas/Vapor, SCFM: } V = 6.32 C K_d P_1 A \frac{1}{\sqrt{T M Z}}$$

$$\text{For Air (ASME Capacity), SCFM: } V = 18.331 \cdot K_d A P_1$$

$$\text{For Liquid, GPM: } Q = 38 \cdot A K_d K_v \sqrt{\frac{P_1 - P_2}{G}}$$

$$\text{For Water(ASME Capacity), GPM: } Q = 38 A K_d \sqrt{P_1 - P_2}$$

#### SLOPE METHOD

$$\text{For Air, SCFM: } V = \text{slope} \cdot P_1$$

$$\text{For Water, GPM: } Q = F \sqrt{P_1 - P_2}$$

MOLECULAR WEIGHT AND VALUES OF "C" FOR GASES					
GAS	M	C	GAS	M	C
AIR	28.97	356	HYDROGEN	2.02	356
ACETYLENE	26.04	345	HYDROGEN SULFIDE	34.08	348
AMMONIA	17.03	351	METHANE	16.04	346
BUTANE	58.12	324	METHYL CHLORIDE	50.48	337
CARBON DIOXIDE	44.01	345	NATURAL GAS (0.6)	17.40	344
CHLORINE	70.91	352	NITROGEN	28.02	356
ETHANE	30.07	339	OXYGEN	32.00	356
ETHYLENE	28.05	337	PROPANE	44.09	331
FREON 22	86.48	355	SULFUR DIOXIDE	64.06	342

NOTE: Air and Water Flow Charts on following pages.

## Air Flow Capacity

AIR FLOW CAPACITY VS. PRESSURE (FOR CONDITIONS SHOWN BELOW)										
ORIFICE	C	D	E	F	G	H	J	K	L	M
ORIFICE DIA. (IN.)	0.281	0.404	0.520	0.674	0.775	1.078	1.350	1.650	2.020	2.280
ORIFICE AREA (SQ.IN.)	0.062	0.128	0.212	0.357	0.472	0.913	1.431	2.138	3.205	4.083
SLOPE	0.998	2.063	3.418	5.742	7.592	14.690	23.038	34.414	51.579	65.711
Kd FACTOR	0.878	0.878	0.878	0.878	0.878	0.878	0.878	0.878	0.878	0.878
SET PRESSURE (PSIG)	CAPACITY IN SCFM. OVERPRESSURE = 110% OR 3 PSI, WHICHEVER IS GREATER									
15	33	67	112	188	248	481	753	1125	1687	2149
20	38	78	129	217	286	554	868	1297	1945	2477
25	43	88	146	245	324	627	983	1469	2202	2806
30	48	98	163	274	362	701	1099	1641	2460	3134
50	70	144	238	400	529	1024	1605	2398	3595	4580
100	124	257	425	716	947	1832	2872	4291	6432	8194
150	179	370	613	1033	1365	2641	4139	6184	9269	11808
200	234	484	801	1349	1783	3449	5405	8076	12106	15422
250	289	597	988	1665	2201	4257	6672	9969	14942	19037
300	344	710	1176	1981	2619	5065	7939	11861	17779	22651
400	454	937	1551	2613	3454	6682	10472	15646	23453	29879
500	563	1163	1927	3245	4290	8298	13006	19431	29127	37107
600	673	1390	2302	3877	5125	9914	15539	23217	34800	44335
700	783	1617	2677	4509	5961	11531	18073	27002	40474	51564
900	1003	2070	3428	5773	7632	14763	23140	34572	51821	66020
1000	1112	2296	3803	6405	8468	16380	25673	38357	57495	73248
1250	1387	2863	4742	7985	10557	20421	32007	47820	71679	
1500	1661	3429	5680	9565	12646	24462	38340	57283		
1750	1936	3996	6618	11145	14735		44674			
2000	2210	4563	7557	12725	16824					
2500	2759	5696	9433	15885						
3000	3308	6829	11310	19046						
4000	4405	9095								
4500	4954	10228								
5000	5503	11361								
6000	6601									
7000	7698									
8000	8796									
9000	9894									
10000	10991									

CONDITIONS						
Temp (°F)	Baro. (psi)	Cp/Cv	Comp. Factor	MW	Density	Gas Const.
60	14.7	1.4	1	28.98	0.0764	356

NOTE: Taylor Valve reserves the right to change product designs and specifications without notice.

## Water Flow Capacity

WATER FLOW CAPACITY VS. PRESSURE (FOR CONDITIONS SHOWN BELOW)										
ORIFICE	C	D	E	F	G	H	J	K	L	M
ORIFICE DIA. (IN.)	0.281	0.404	0.520	0.674	0.775	1.078	1.350	1.650	2.020	2.280
ORIFICE AREA (SQ.IN.)	0.062	0.128	0.212	0.357	0.472	0.913	1.431	2.138	3.205	4.083
FLOW FACTOR	1.963	4.058	6.722	11.293	14.932	28.890	45.308	67.682	101.440	129.233
Kd FACTOR	0.833	0.833	0.833	0.833	0.833	0.833	0.833	0.833	0.833	0.833
SET PRESSURE (PSIG)	CAPACITY IN GPM. OVERPRESSURE = 110% OR 3 PSI, WHICHEVER IS GREATER									
15	8	17	28	48	63	123	192	287	430	548
20	9	19	32	54	72	139	217	325	487	620
25	10	21	36	60	79	153	240	358	537	684
30	11	23	39	65	86	166	260	389	583	742
50	15	30	50	84	111	214	336	502	752	958
100	21	42	70	119	157	303	475	710	1064	1356
150	25	52	86	145	192	371	582	869	1303	1660
200	29	60	100	168	222	429	672	1004	1505	1917
250	33	67	111	187	248	479	751	1122	1682	2143
300	36	74	122	205	271	525	823	1229	1843	2348
400	41	85	141	237	313	606	950	1420	2128	2711
500	46	95	157	265	350	678	1062	1587	2379	3031
600	50	104	172	290	384	742	1164	1739	2606	3320
700	54	112	186	314	415	802	1257	1878	2815	3586
900	62	127	211	356	470	909	1425	2129	3192	4067
1000	65	134	223	375	496	958	1502	2244	3365	4287
1250	73	150	249	419	554	1072	1680	2509	3762	
1500	80	165	273	459	607	1174	1840	2749		
1750	86	178	294	496	655		1987			
2000	92	190	315	530	701					
2500	103	212	352	593						
3000	113	233	385	649						
4000	130	269								
4500	138	285								
5000	146	300								
6000	159									
7000	172									
8000	184									
9000	195									
10000	206									

  

CONDITIONS					
Temp (°F)	Baro. (psi)	SG	Back Pressure	Kv	Specific Weight
70	14.7	1	0	1	62.3058

NOTE: Taylor Valve reserves the right to change product designs and specifications without notice.

# Part Numbering System

825 **Y** **A** **B** **C** **D** **E** **F** **G** - **HI** - **JK** - **L** (Disregard HI-JK-L if connections are not flanged)

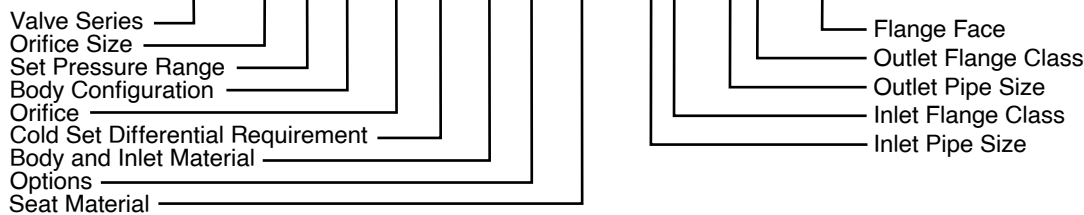

ORIFICE SIZE	
Y	C
	D
	E
	F
	G
	H
	J
	K
	L
	M

PRESSURE RANGE (Standard Spring 17-7 SS)										
CODE	ORIFICE									
	"C"	"D"	"E"	"F"	"G"	"H"	"J"	"K"	"L"	"M"
1	-	15-40	15-23	-	-	15-23	-	-	15-25	15-22
2	-	41-100	24-50	15-35	15-25	24-56	15-35	15-20	26-50	23-42
3	300-450	101-215	51-125	36-70	26-50	57-90	36-55	21-35	51-70	43-60
4	451-700	216-350	126-190	71-110	51-79	91-170	56-100	36-60	71-80	61-70
5	701-1300	351-600	191-340	111-180	80-130	171-230	101-140	61-80	81-100	71-85
6	1301-2600	601-1200	341-700	181-400	131-260	231-320	141-175	81-95	101-190	86-150
7	2601-4000	1201-2000	701-1100	401-600	261-450	321-650	176-250	96-105	191-300	151-250
8	4001-6000	2001-2800	1101-1500	601-950	451-670	651-1000	251-350	106-165	301-450	251-360
9	6001-8500	2801-3700	1501-2250	951-1100	671-800	1001-1600	351-450	166-250	451-750	361-660
0	8501-10000	3701-5000	2251-3000	1101-1350	801-1500		451-540	251-300	751-1250	661-1000
10				1351-1500	1501-2000		541-830*	301-400*		
11				1501-2000			831-1000*	401-550*		
12				2001-3000			1001-1800**	551-650*		
13								651-1200**		
14								1201-1500**		

PRESSURE RANGE (NACE Spring 316ST, MP35N, X750, ELGILOY, or Equivalent)										
CODE	ORIFICE									
	"C"	"D"	"E"	"F"	"G"	"H"	"J"	"K"	"L"	"M"
1	-	15-30	15-21	-	-	15-25	-	-	15-30	15-25
2	-	31-90	22-50	15-30	15-25	26-65	15-35	15-25	31-50	26-45
3	300-400	91-200	51-100	31-65	26-45	66-130	36-70	26-45	51-75	46-65
4	401-750	201-350	101-200	66-110	46-80	131-250	71-100	46-64	76-100	66-80
5	751-1300	351-600	201-350	111-200	81-140	251-350	101-135	65-85	101-200	81-160
6	1301-2500	601-1200	351-700	201-410	141-300	351-700	136-160	86-100	201-325	161-270
7	2501-4000	1201-2000	701-1100	411-775	301-555	701-1100	161-180	101-110	326-450	271-360
8	4001-6000	2001-2800	1101-1500	776-1100	556-725	1101-1500	181-290	111-180	451-800	361-700
9	6001-10,000	2801-5000	1501-2100	1101-1500	726-1600		291-375	181-250		
0			2101-2750	1501-2000	1601-2000		376-610*	251-390*		
10				2001-3000			611-1000*	391-650*		

\*TOP ENTRY  
\*\*FLANGED ONLY

"L" orifice over 285psi shall be 4 x 6 only

INLET & OUTLET		
SRV 1		
0	1/2 MNPT X 1 FNPT	C & D
1	1/2 FNPT X 1 FNPT	C & D
2	3/4 MNPT X 1 FNPT	C, D & E
3	1 MNPT X 1 FNPT	C, D & E
4	3/4 FNPT X 1 FNPT	C, D & E
5	3/4 MNPT X 1-1/2 FNPT	C, D & E
6	1 MNPT X 1-1/2 FNPT	C, D & E
7	FLANGED	C, D & E
8	1 FNPT X 1-1/2 FNPT	C, D & E
9	1 FNPT X 1 FNPT	C, D & E
10	1/2 MNPT X 1-1/2 FNPT	C & D
11	3/4 FNPT X 1-1/2 FNPT	C, D & E
12	3/4 MNPT X 1-1/4 FNPT	C, D & E
14	1/2 MNPT X 3/4 FNPT	D
15	3/4 MNPT X 3/4 FNPT	D
16	1/2 FNPT X 3/4 FNPT	D
17	3/4 FNPT X 3/4 FNPT	D
18	1/2 FNPT X 1-1/2 FNPT	C & D
SRV 2		
1	2 MNPT x 2-1/2 FNPT	F, G & H
3	1-1/2 FNPT X 2 FNPT	F, G & H
5	1-1/2 MNPT X 2 FNPT	F, G & H
6	2 MNPT X 2 FNPT	F, G & H
7	2 FNPT X 2 FNPT	F, G & H
8	FLANGED	F, G & H
9	2 FNPT X 2-1/2 FNPT	F, G & H
10	1-1/2 MNPT X 2-1/2 FNPT	F, G & H
13	1 MNPT X 2 FNPT	F Only
14	1 FNPT X 2 FNPT	F Only
SRV 3		
Threaded: Max Set 1000psi J/650psi K		
2	2 MNPT X 3 FNPT	J ONLY
3	3 FNPT X 3 FNPT	J ONLY
4	2-1/2 MNPT X 3 FNPT	J & K
5	2 FNPT X 3 FNPT	J ONLY
7	3 MNPT X 3 FNPT	J & K
8	FLANGED	J, K, & L
SRV 4 - TOP ENTRY FLANGED ONLY		
4	4 x 6	L & M

## ELASTOMERS CHART

MATERIAL	TEMPERATURE RANGE °F		SEAT PRESSURE		APPLICATIONS
	MIN	MAX	MIN	MAX	
FKM	-15	400	15	999	Hydrocarbons, H2S, Mineral Oil/Grease, Silicone Oil/Grease, Chlorinated Hydrocarbons, Fuels
NBR	-30	250	15	999	Hydrocarbons, CO2, Dilute Acids, Water, H2S
EPDM	-70	500	15	999	Glycols, Organic Acids, Inorganic Acids, Hydraulic Fluids, Solvents
PTFE	-420	450	250*	2,000	Cryogenics, Strong Acids, Amines
PEEK	-60	450	1,000	10,000	Dilute acids, Glycol, Methanol, Aldehyds, Esters, Water
LO-TEMP NBR	-70	180	**	**	Petroleum Oils, Water (Up To 212F), Salt & Alkali Solutions, Weak Acids
AFLAS	+25	450	**	**	Bases, Sour Oil & Gas, Steam, Phosphate Esters, Amines, Petroleum Oils, Acids, Ozone, Alcohols
VG109	-50	400	**	**	Mineral Oil and Grease, Nonflammable Hydraulic Fluids, Silicone Oils and Greases, Aliphatic Hydrocarbons, Aromatic Hydrocarbons, Chlorinated Hydrocarbons, Gasoline, High Vacuum, Ozone, Weather, and Aging Resistance
HNBR/HSN	-25	300	**	**	Hydrocarbons, CO2, H2S, Dilute Acids, Water and Steam Less than 300°F
KALREZ FFKM (6375)	-4	525	**	**	Water, Glacial Acetic Acid, Nitric Acid (70%), Sulfuric Acid (98%), Maleic Acid, Ammonium Hydroxide, Ethylene Oxide, Urea, Epichlorohydrin, Butyraldehyde, Toluene Diisocyanate, HCFC 134a
NEOPRENE	-35	225	**	**	Carbon Dioxide, Ammonia, Refrigerants, Silicone Oil and Grease, Water and Water Solvents at Low Temperatures

\* Consult Taylor Valve for optional pressure configurations

\*\* Uses PTFE or PEEK Seat only. Set pressures will follow PTFE and PEEK limits

**C**

ORIFICE CODE	
CODE	ORIFICE
1	J
2	K
3	L
4	C or D
5	E or G
6	F
7	H
8	M

**D**

COLD SET DIFFERENTIAL REQUIREMENT	
CODE	TEMPERATURE
1	AMBIENT

**E**

BODY & INLET MATERIAL <sup>^</sup>	
CODE	MATERIAL
3	CARBON STEEL
5	STAINLESS STEEL
6	CS BODY/SS INLET*
7	CS BODY/316 INTERNALS**
8	SS BODY/316 INTERNALS**
9	CS BODY/SS SEAT FRAME/ 316 INTERNALS*

**F**

TOP STYLE / OPTIONS	
CODE	SERIES
0	OPEN Lift Lever (LL)
1	CLOSED TOP
3	CLOSED Lift Lever
4	NACE
5	1/4 NPT TAP^^
6	LL w/1/4 NPT TAP^^
8	Lift Lever/NACE
9	1/4 TAP/NACE^^

<sup>^</sup> 17-4 SST (STANDARD INT)

\* N/A- H, J, K, L, M (TOP ENTRY, BODY/SF, ONE PC DESIGN)

\*\* 316INT MAX PRESSURE RATING 2800 PSI

^^THREADED ONLY

**Note:** C ORIFICE PRESSURES OVER 4000 PSI 17-4 SEATFRAME ONLY  
F ORIFICE FOR 2"FNPT PRESSURES OVER 2800 PSI 316 SEATFRAME ONLY

**G**

ELASTOMER MATERIALS			
1	FKM SEAT/SEALS	B	PTFE SEAT/NBR SEALS
2	PTFE SEAT/FKM SEALS	C	PTFE SEAT/EPDM SEALS
5	PEEK SEAT/FKM SEALS	D	PTFE SEAT/LO-TEMP NBR SEALS
7	NBR SEAT/SEALS	E	PEEK SEAT/NBR SEALS
9	EPDM SEAT/SEALS	F	PTFE SEAT/FFKM (KALREZ) SEALS
0	PTFE SEAT/NEOPRENE SEALS	G	PEEK SEAT/FFKM (KALREZ) SEALS
		H	NBR SEAT/FFKM (KALREZ) SEALS
		I	PEEK SEAT/LO-TEMP NBR
		J	PEEK SEAT/EPDM SEALS
		K	PEEK SEAT/HNBR-HSN SEALS
		M	PTFE SEAT/AFLAS SEALS
		N	PTFE SEAT/HNBR-HSN SEALS
		P	PEEK SEAT/VG109 SEALS
		V	PTFE SEAT/VG109 SEALS

**Note:** C - Orifice PTFE or PEEK inserts only depending on pressure  
L - Orifice PTFE only over 50 psi  
M - Orifice PTFE inserts only

**HI**

HI - INLET FLANGE SIZE & CLASS			
H	PIPE SIZE	I	FLANGE CLASS
<b>SRV 1 - C, D, E</b>			
0	3/4"	0	150
1	1"	1	300
3	1-1/2"	3	600 (heaviest flange offered on L and M)
		4	900 (2.5" pipe and under use 1500 option, heaviest flange offered on J and K)
		5	1500
<b>SRV 2 - F, G, H</b>			
3	1-1/2"		
4	2"		
5	2-1/2"		
6	3"		
<b>SRV 3 - J, K, L</b>			
4	2" (J ONLY)		
5	2-1/2" (J ONLY)		
6	3"		
<b>SRV 4 - L &amp; M</b>			
7	4"		

**JK**

JK - OUTLET FLANGE SIZE & CLASS			
J	PIPE SIZE	K	FLANGE CLASS
<b>SRV 1 - C, D, E</b>			
1	1"	0	150
3	1-1/2"	1	300 (NO J, K, L, or M)
4	2"	3	600 (NO J, K, L, or M)
<b>SRV 2 - F, G, H</b>			
4	2"		
5	2-1/2"		
6	3"		
<b>SRV 3 - J, K, L</b>			
6	3" (J ONLY)		
7	4"		
<b>SRV 4 - L &amp; M</b>			
8	6"		

**L**

FLANGE SEAL FACES (Inlet & Outlet)		
	TYPE	AVAILABILITY
0	RFF X RFF	SRV 1, 2, 3, 4
1	RFF X RTJ	SRV 1 & 2
2	RTJ X RFF	SRV 1 & 2
3	RTJ X RTJ	SRV 1 & 2

**EX: 825E4351311 Set @ 135 psi**

- 825** - 825 - 8250 Series Relief Valve
- E** - "E" Orifice
- 4** - Spring Range of 126-190
- 3** - 1"MNPT X 1"FNPT Connections
- 5** - "E" Orifice
- 1** - Ambient Operating Temperature
- 3** - Carbon Steel Body
- 1** - Closed Top
- 1** - FKM Seat and O-Rings

**EX: 825G485151B-43-40-0 Set @ 75 psi**

- 825** - 8250 Series Relief Valve
- G** - "G" Orifice
- 4** - Spring Range 51-79
- 8** - Flanged Connection's
- 5** - "G" Orifice
- 1** - Ambient Set
- 5** - Stainless Steel Body
- 1** - Closed Top
- B** - PTFE Seat and NBR O-Rings
- 43** - 2" SIZE / CLASS 600 Flange Inlet
- 40** - 2" SIZE / CLASS 150 Flange Outlet
- 0** - RFF X RFF Flanged Sealing Faces



Taylor Valve Technology  
8300 S.W. 8th Street  
Oklahoma City, Oklahoma 73128

TEL 405.787.0145  
FAX 800.805.3401  
WEB [www.taylorvalve.com](http://www.taylorvalve.com)  
EMAIL [info@taylorvalve.com](mailto:info@taylorvalve.com)



Precise.

Quality.

Reliable.