

# 19BV SERIES Pressure Relief Valve

TRUSTED  
**SINCE 1958**  
WORLDWIDE

Precise.

Quality.

Reliable.



## BALANCED DISC PRESSURE RELIEF VALVE

The 19BV is an economic, direct spring operated, soft-seated, balanced valve incorporating balanced disc and cage guided assembly creating optimal performance in both liquid and air service where built up or superimposed backpressure could be an issue.

The seat at the inlet orifice, and the area of the o-ring guided disc in the cage are equal. The disc/cage assembly uses a plastic bubble tight seat at the inlet nozzle for upstream pressures and an o-ring guided disc in the cage as the balanced seal for downstream backpressure. The vented to atmosphere upper body allows the valve's balanced disc/cage assembly to remain fully functional in superimposed backpressure conditions having little to no effect on set pressure.

A cost savings answer to the high-end bellows valves, in a simple and reliable design.



### Features of the 19BV below:

- ◆ Soft seat for reliable, leak free performance to 90% of set pressure
- ◆ Easy repair and maintenance
- ◆ Balanced disc/cage assembly designed with a single o-ring balancing seal to operate in high back pressure conditions.
- ◆ Optimized design allows the valve to operate without chatter or intricate seals.
- ◆ ASME certified by the National Board of Boiler and Pressure Vessels in accordance to Sec VIII Div I for air/gas and liquid service.
- ◆ NPT threaded and flanged connections

### APPLICATIONS:

The Taylor 19BV Pressure Relief Valve has numerous application uses. Since the Series 19BV is certified for both gas and liquid on both orifices, it can be installed where relief applications that have variable back pressure are present. Thermal valves, pump recycle, separators (liquid side), water knockouts, etc. are just a few examples of application uses.

# Table of Contents

## Specifications/Material Overview

1" 19BV.....	4-5
Flow Capacity.....	6
Flow Capacity Calculations.....	7
Connection Dimensions.....	8

## Ordering

Part Numbering System.....	8
----------------------------	---

## 19BV .250 (Orifice Diameter)

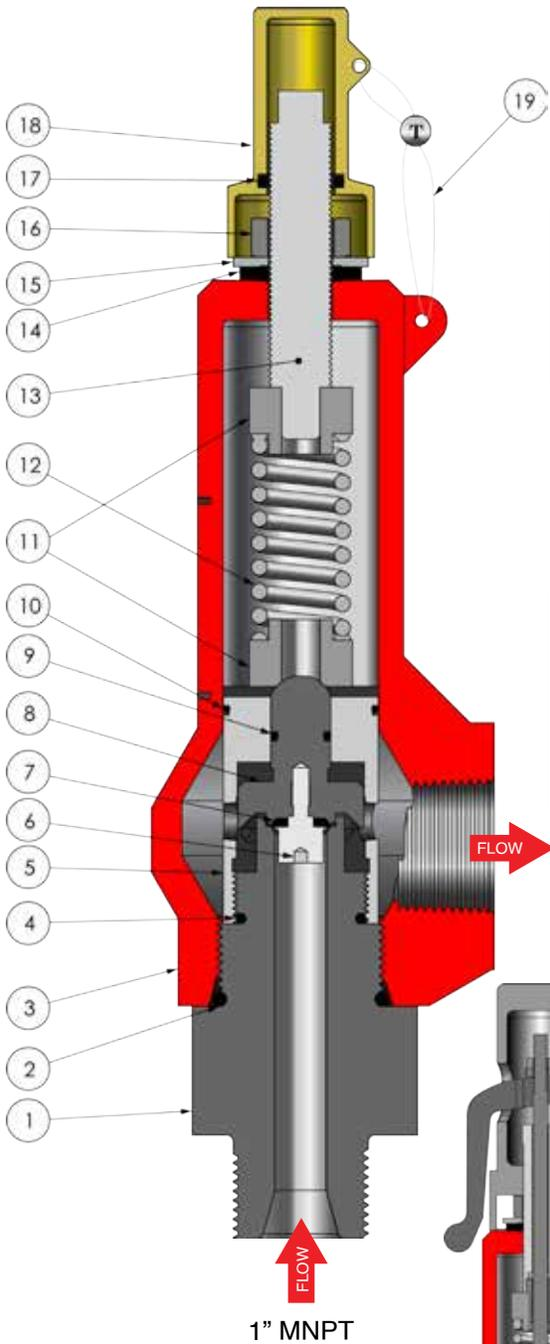

ITEM	PART	STANDARD CLOSED TOP CONFIGURATION			
		STANDARD APPLICATIONS		NACE APPLICATIONS	
		CARBON STEEL	STAINLESS STEEL	CARBON STEEL	STAINLESS STEEL
1	Inlet Nozzle	316 SS SA479	316 SS SA479	316 SS SA479	316 SS SA479
2	O-ring	Specify	Specify	Specify	Specify
3	Body	2A216 GR WCC	SA351 CF8M	2A216 GR WCC	SA351 CF8M
4	O-ring	Specify	Specify	Specify	Specify
5	Cage	316 SS SA479	316 SS SA479	316 SS SA479	316 SS SA479
6	Seat Retainer	316 SS SA479	316 SS SA479	316 SS SA479	316 SS SA479
7	Seat Insert	PTFE	PTFE	PTFE	PTFE
8	Disc	316 SS SA479	316 SS SA479	316 SS SA479	316 SS SA479
9	O-ring	Specify	Specify	Specify	Specify
10	O-ring	Specify	Specify	Specify	Specify
11	Spring Keeper	316 SS SA479	316 SS SA479	316 SS SA479	316 SS SA479
12	Spring	17-7SS SA564	17-7PH SS SA564	Consult Factory*	Consult Factory*
13	Adjustment Screw	1018/1020CS A108	304 SS SA479	304 SS SA479	304 SS SA479
14	Thread Seal	Buna/Steel	Buna/Steel	Buna/Steel	Buna/Steel
15	Flat Washer	CS ANSI B18.22.1	18-8SS	CS ANSI B18.22.1	18-8SS
16	Jam Nut	CS ANSI B18.22.1	18-8SS	CS ANSI B18.2.2	18-8SS
17	O-ring	PC BUNA	PC BUNA	PC BUNA	PC BUNA
18	Cap	CS/ZINC	SS/CF3M	CS/ZINC	SS/CF3M
19	Lead Seal Wire	SS	SS	SS	SS
20 <sup>1</sup>	Data Label	SS	SS	SS	SS
21 <sup>1</sup>	Drive Screws	18-8 SS	18-8 SS	18-8 SS	18-8 SS

\* Nace springs- 316SS, MP35N, ELGILOY, OR INCONEL

<sup>1</sup> These parts are not shown

Inlet Sizes: 1/2" (flanged only), 3/4", 1"  
 Connections: NPT, Flanged  
 Temperature Range: -65°F to +400°F (-54°C to +205°C)  
 Set Pressure: 50 to 1,600 psig  
 Code: ASME Sec VIII Div 1

### Lift Lever

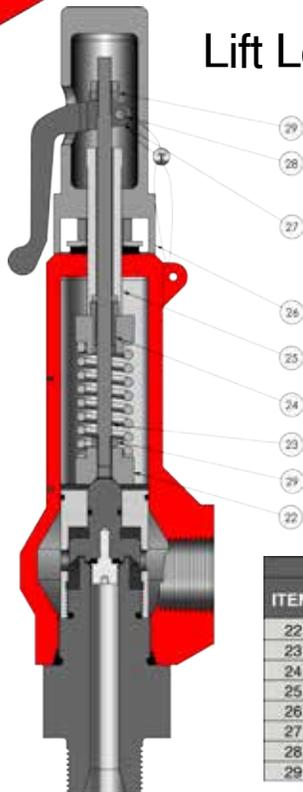

### Inlet Thread Options

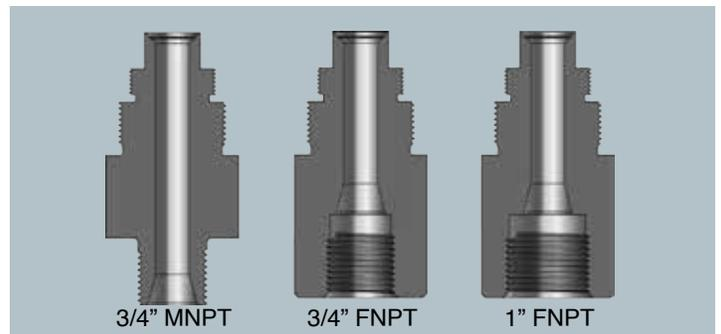

ITEM	PART	LIFT LEVER CONFIGURATION			
		STANDARD APPLICATION		NACE APPLICATION	
		CARBON STEEL	STAINLESS STEEL	CARBON STEEL	STAINLESS STEEL
22	LL Spring Keeper	316 SS SA479	316 SS SA479	316 SS SA479	316 SS SA479
23	Stem Extension	304 SS SA479	304 SS SA479	304 SS SA479	304 SS SA479
24	O-Ring Follower	304 SS SA479	304 SS SA479	304 SS SA479	304 SS SA479
25	Adjustment Screw	17-4SS SA564	17-4SS SA564	17-4SS SA564	17-4SS SA564
26	Lift Lever Cap	304 SS SA479	304 SS SA479	304 SS SA479	304 SS SA479
27	Lift Handle	Aluminum Bronze	Aluminum Bronze	Aluminum Bronze	Aluminum Bronze
28	Clevis Pin	316 SS SA479	316 SS SA479	316 SS SA479	316 SS SA479
29	Lock Nut	Steel	Steel	Steel	Steel

NOTE: Taylor Valve reserves the right to change product designs and specifications without notice.

## 19BV .500 (Orifice Diameter)

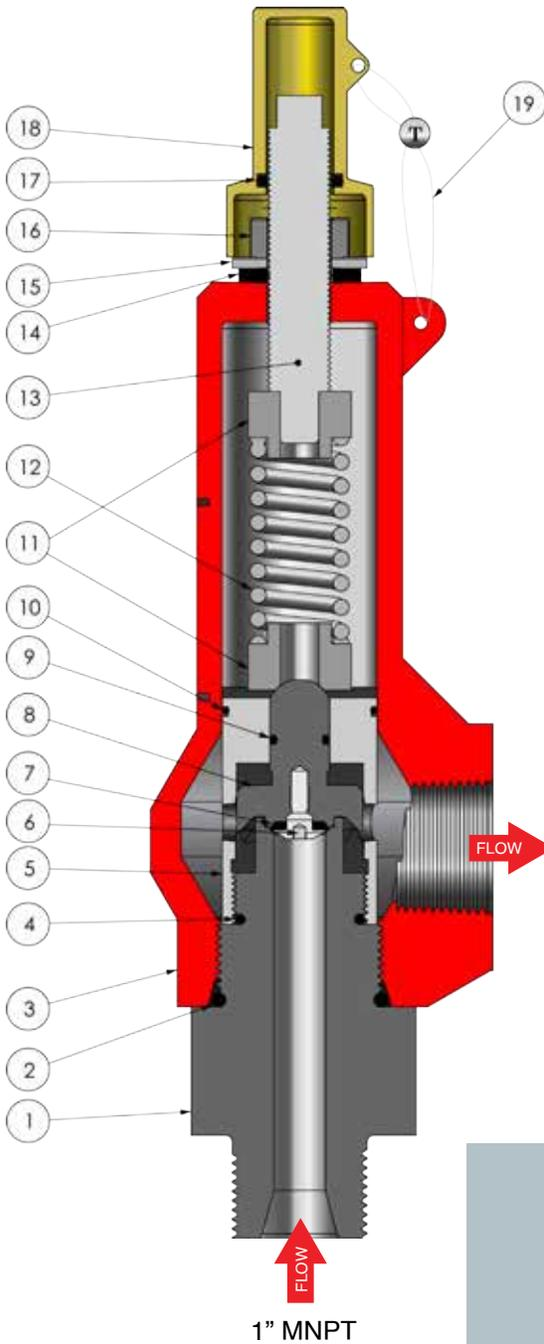

ITEM	PART	STANDARD APPLICATIONS		NACE APPLICATIONS	
		CARBON STEEL	STAINLESS STEEL	CARBON STEEL	STAINLESS STEEL
1	Inlet Nozzle	316 SS SA479	316 SS SA479	316 SS SA479	316 SS SA479
2	O-ring	Specify	Specify	Specify	Specify
3	Body	2A216 GR WCC	SA351 CF8M	2A216 GR WCC	SA351 CF8M
4	O-ring	Specify	Specify	Specify	Specify
5	Cage	316 SS SA479	316 SS SA479	316 SS SA479	316 SS SA479
6	Seat Retainer	316 SS SA479	316 SS SA479	316 SS SA479	316 SS SA479
7	Seat Insert	PTFE	PTFE	PTFE	PTFE
8	Disc	316 SS SA479	316 SS SA479	316 SS SA479	316 SS SA479
9	O-ring	Specify	Specify	Specify	Specify
10	O-ring	Specify	Specify	Specify	Specify
11	Spring Keeper	316 SS SA479	316 SS SA479	316 SS SA479	316 SS SA479
12	Spring	17-7SS SA564	17-7PH SS SA564	Consult Factory*	Consult Factory*
13	Adjustment Screw	1018/1020CS A108	304 SS SA479	304 SS SA479	304 SS SA479
14	Thread Seal	Buna/Steel	Buna/Steel	Buna/Steel	Buna/Steel
15	Flat Washer	CS ANSI B18.22.1	18-8SS	CS ANSI B18.22.1	18-8SS
16	Jam Nut	CS ANSI B18.22.1	18-8SS	CS ANSI B18.22.2	18-8SS
17	O-ring	PC BUNA	PC BUNA	PC BUNA	PC BUNA
18	Cap	CS/ZINC	SS/CF3M	CS/ZINC	SS/CF3M
19	Lead Seal Wire	SS	SS	SS	SS
20 <sup>1</sup>	Data Label	SS	SS	SS	SS
21 <sup>1</sup>	Drive Screws	18-8 SS	18-8 SS	18-8 SS	18-8 SS

\* Nace springs- 316SS, MP35N, ELGILOY, OR INCONEL

<sup>1</sup> These parts are not shown

Inlet Sizes: 3/4", 1"  
 Connections: NPT, Flanged  
 Temperature Range: -65°F to +400°F (-54°C to +205°C)  
 Set Pressure: 50 to 1,600 psig  
 Code: ASME Sec VIII Div 1

### Lift Lever

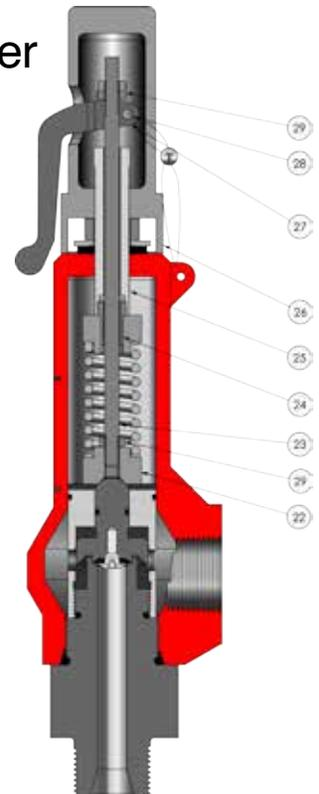

### Inlet Thread Options

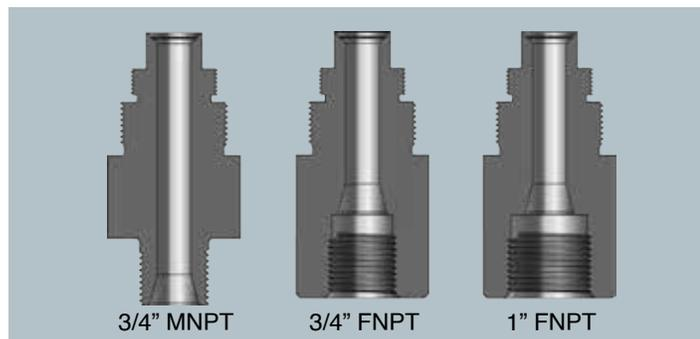

ITEM	PART	STANDARD APPLICATION		NACE APPLICATION	
		CARBON STEEL	STAINLESS STEEL	CARBON STEEL	STAINLESS STEEL
22	LL Spring Keeper	316 SS SA479	316 SS SA479	316 SS SA479	316 SS SA479
23	Stem Extension	304 SS SA479	304 SS SA479	304 SS SA479	304 SS SA479
24	O-Ring Follower	304 SS SA479	304 SS SA479	304 SS SA479	304 SS SA479
25	Adjustment Screw	17-4SS SA564	17-4SS SA564	17-4SS SA564	17-4SS SA564
26	Lift Lever Cap	304 SS SA479	304 SS SA479	304 SS SA479	304 SS SA479
27	Lift Handle	Aluminum Bronze	Aluminum Bronze	Aluminum Bronze	Aluminum Bronze
28	Clevis Pin	316 SS SA479	316 SS SA479	316 SS SA479	316 SS SA479
29	Lock Nut	Steel	Steel	Steel	Steel

## FLOW CAPACITY CHARTS

AIR FLOW CAPACITY VS. PRESSURE (FOR CONDITIONS SHOWN BELOW)		
ORIFICE	1/4	1/2
ORIFICE DIA. (IN.)	0.250	0.500
ORIFICE AREA (SQ.IN.)	0.049	0.196
SLOPE	0.76	3.03
Kd FACTOR	0.845	0.842
SET PRESSURE (PSIG)	CAPACITY IN SCFM. OVERPRESSURE = 110%	
50	52	211
75	73	294
100	94	377
125	115	461
150	136	544
175	157	627
200	178	711
250	220	877
300	261	1044
350	303	1211
400	345	1377
450	387	1544
500	429	1711
550	470	1877
600	512	2044
650	554	2210
700	596	2377
750	638	2544
800	679	2710
900	763	3044
1000	847	3377
1100	930	3710
1200	1014	4044
1300	1097	4377
1400	1181	4710
1500	1265	5044
1600	1348	5377

WATER FLOW CAPACITY VS. PRESSURE (FOR CONDITIONS SHOWN BELOW)		
ORIFICE	1/4	1/2
ORIFICE DIA. (IN.)	0.250	0.500
ORIFICE AREA (SQ.IN.)	0.049	0.196
SLOPE	1.25	4.79
Kd FACTOR	0.670	0.642
SET PRESSURE (PSIG)	CAPACITY IN GPM. OVERPRESSURE = 110%	
50	9.2	35
75	11.3	43
100	13.1	50
125	14.6	56
150	16.0	61
175	17.3	66
200	18.5	71
250	20.7	79
300	22.7	87
350	24.5	93
400	26.2	100
450	27.8	106
500	29.3	112
550	30.7	117
600	32.1	123
650	33.4	128
700	34.6	132
750	35.9	137
800	37.0	142
900	39.3	150
1000	41.4	158
1100	43.4	166
1200	45.4	174
1300	47.2	181
1400	49.0	187
1500	50.7	194
1600	52.4	200

CONDITIONS						
Temp (°F)	Baro. (psi)	Cp/Cv	Comp. Factor	MW	Density	Gas Const.
60	14.7	1	1	28.98	0.0764	356

CONDITIONS					
Temp (°F)	Baro. (psi)	SG	Back Pressure	Kv	Specific Weight
70	14.7	1	0	1	62.3058

## FLOW CAPACITY CALCULATION

### WHERE:

- V = Volumetric Flow Rate, SCFM
- W = Mass Flow-rate, lb/hr
- Q = Volumetric Flow Rate, GPM
- C = constant for Gas or Vapor based on ratio of specific heats, k (Cp/Cv)
- A = orifice throat area, square inches
- $K_d$  = Rated Coefficient of Discharge
- M = molecular weight
- P<sub>1</sub> = (stamped set pressure + 3 psi or 10%, whichever is greater) + 14.7 psia
- P<sub>d</sub> = pressure at the discharge of the valve, psia
- T = absolute temperature at inlet, °R (degrees Fahrenheit + 460)
- slope = value determined by the ASME through testing at the National Board Test Lab, Columbus, OH; for Air and Gas service, SCFM/psia
- F = value determined by the ASME through testing at the National Board Test Lab, Columbus, OH; for Liquid service, GPM/ sqrt(PSID)
- G = Specific Gravity
- Z = compressibility factor for gas or vapor, (=1 if unknown)
- $K_v$  = Viscosity Correction Factor calculated from Reynold's Number and Viscosity (=1 if unknown)

### FLOW CAPACITY CHARTS & FORMULAS

To determine the relieving capacity which should appear on a valve for a given pressure, use either the Coefficient Method or Slope Method.

#### COEFFICIENT METHOD

For Gas/Vapor, lb/hr:  $W = ACK_d P_1 \sqrt{\frac{M}{T}}$

For Gas/Vapor, SCFM:  $V = 6.32 CK_d P_1 A \frac{1}{\sqrt{TMZ}}$

For Air (ASME Capacity), SCFM:  $V = 18.331 K_d A P_1$

For Liquid, GPM:  $Q = 38 \cdot AK_d K_v \sqrt{\frac{P_1 - P_2}{G}}$

For Water(ASME Capacity), GPM:  $Q = 38 AK_d \sqrt{P_1 - P_2}$

#### SLOPE METHOD

For Air, SCFM:  $V = \text{slope} \cdot P_1$

For Water, GPM:  $Q = F \sqrt{P_1 - P_2}$

MOLECULAR WEIGHT AND VALUES OF "C" FOR GASES					
GAS	M	C	GAS	M	C
AIR	28.97	356	HYDROGEN	2.02	356
ACETYLENE	26.04	345	HYDROGEN SULFIDE	34.08	348
AMMONIA	17.03	351	METHANE	16.04	346
BUTANE	58.12	324	METHYL CHLORIDE	50.48	337
CARBON DIOXIDE	44.01	345	NATURAL GAS (0.6)	17.40	344
CHLORINE	70.91	352	NITROGEN	28.02	356
ETHANE	30.07	339	OXYGEN	32.00	356
ETHYLENE	28.05	337	PROPANE	44.09	331
FREON 22	86.48	355	SULFUR DIOXIDE	64.06	342

NOTE: Air and Water Flow Charts on previous pages.

## CONNECTION DIMENSIONS

1" THREADED VALVE

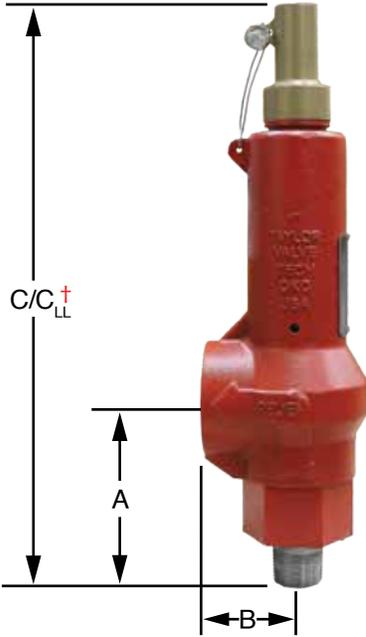

Flange						
ORIFICE	INLET X OUTLET (inches)	INLET FLANGE CLASS*	DIMENSIONS (in)			
			A	B	C	C <sub>LL</sub> †
1/4"	1/2 X 1	150	4.82	4.75	12.96	14.54
		300	4.82	4.75	12.96	14.54
		600	4.97	4.75	13.11	14.69
		900	4.97	4.75	13.11	14.69
		1500	4.97	4.75	13.11	14.69
		2500	5.97	6.75	14.11	15.69
1/4" 1/2"	3/4 X 1	150	4.72	4.75	12.86	14.44
		300	4.72	4.75	12.86	14.44
		600	4.72	4.75	12.86	14.44
		900	4.72	4.75	12.86	14.44
		1500	4.72	4.75	12.86	14.44
		2500	5.72	6.75	13.86	15.44
	1 X 1	150	4.72	4.75	12.86	14.44
		300	4.72	4.75	12.86	14.44
		600	4.72	4.75	12.86	14.44
		900	5.72	6.75	13.86	15.44
		1500	5.72	6.75	13.86	15.44
		2500	5.72	6.75	13.86	15.44

 \*DIMENSIONS DO NOT VARY WITH OUTLET FLANGE CLASS  
 † PERTAINS TO THE LIFT LEVER OPTION

Threaded						
ORIFICE	INLET	OUTLET	DIMENSIONS (in)			
			A	B	C	C <sub>LL</sub> †
1/4" 1/2"	3/4" MNPT	1" FNPT	3.80	1.88	11.94	13.52
	3/4" FNPT		3.70	1.88	11.84	13.42
	1" MNPT		3.80	1.88	11.94	13.52
	1" FNPT		3.70	1.88	11.84	13.42

## PART NUMBERING SYSTEM

**19- A BB C E F G - H I J K - L**

Orifice	Spring		Body Material		Options		O-ring Material		Seat Material															
	A	BB	C		E		F		G															
2	.250" (.049 in <sup>2</sup> )	02 50-62	5	Stainless Steel	1	Standard (Closed Top)	1	FKM	4	PTFE														
5	.500" (.196 in <sup>2</sup> )	03 63-130	6	CS Body/SS Inlet	3	Lift Lever (LL)	2	Buna																
		04 131-205									5	NACE	3	EPDM										
		05 206-360													6	NACE & LL	4	Neoprene						
		06 361-750																	5	FFKM				
		07 751-1200																			6	Lo-Temp NBR		
		08 1201-1600																					7	Aflas



Inlet Size	Inlet Class	Outlet Size	Outlet Class
H	I	J	K
0	1/2"	0	150
1	3/4"	1	300
2	1"	2	600
		3	900
		4	1500
		5	2500
		7	MNPT
		8	FNPT

**Flanged Only**

Flange Faces	L
0	RFF x RFF
1	RFF x RTJ
2	RTJ x RFF
3	RTJ x RTJ



Taylor Valve Technology  
8300 S.W. 8th Street  
Oklahoma City, Oklahoma 73128

TEL 405.787.0145  
FAX 800.805.3401  
WEB [www.taylorvalve.com](http://www.taylorvalve.com)  
EMAIL [info@taylorvalve.com](mailto:info@taylorvalve.com)

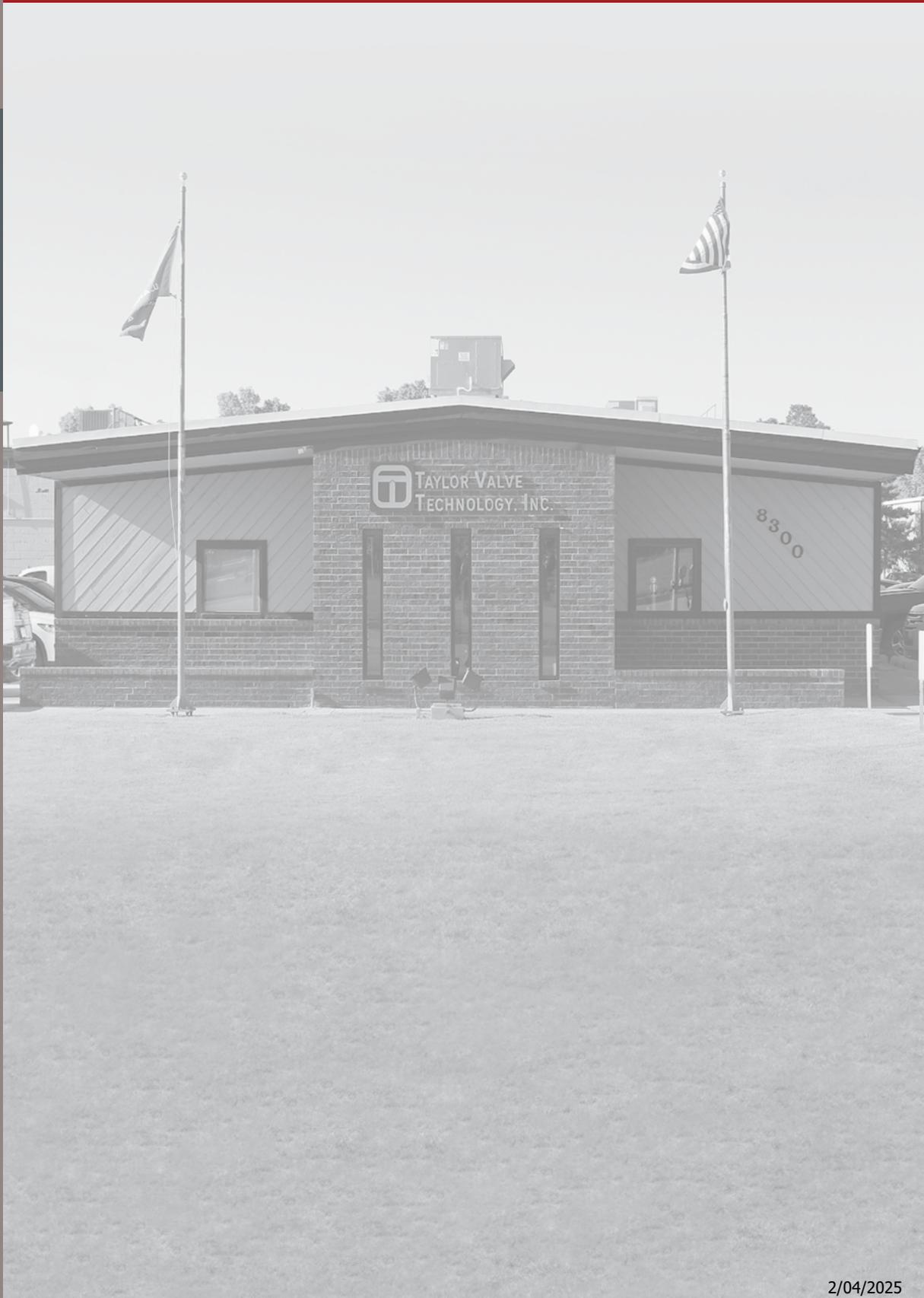

Precise.

Quality.

Reliable.