

TRUSTED
SINCE 1958
WORLDWIDE

Precise.

Quality.

Reliable.



8400 SERIES VAPOR VALVE

FEATURES & Benefits

The 8400 Series Vapor Valve provides pressure relief in applications where hazardous vapors are to be piped away. The Vapor Valve is a non-ASME code valve, and specifically addresses low-pressure applications (below 15 PSIG). The valve uses a spring which directly opposes system pressure. A fully-guided, stainless steel disc senses the system pressure. If the system pressure ever reaches the valve's determined set pressure, the disc will release from its seated position, venting system pressure.

Applications: Glycol Reboiler Safety Relief, BTEX Safety Relief, Tank Blanketing, and Vessel Safety Relief below 15 PSIG

SPECIFICATIONS

Flow Diameter	Pressure Range	Standard Connections
Full Bore	2.2 oz/in ² to 14.7 psig	1" MNPT x 1" FNPT
Full Bore	2.0 oz/in ² to 14.7 psig	2" MNPT x 2" FNPT

DIMENSIONS & WEIGHTS

Connection Size		Threaded Connections		Dimensions						Approximate Weight	
Inlet	Outlet	Inlet	Outlet	A		B		C		lbs	kg
				inches	mm	inches	mm	inches	mm		
1"	1"	MNPT	FNPT	3-1/4	82.5	1-7/8	47.63	9-13/16	249	4.3	1.95
2"	2"	MNPT	FNPT	4-1/4	107.95	2-5/16	58.74	10-9/16	268	11.6	5.26

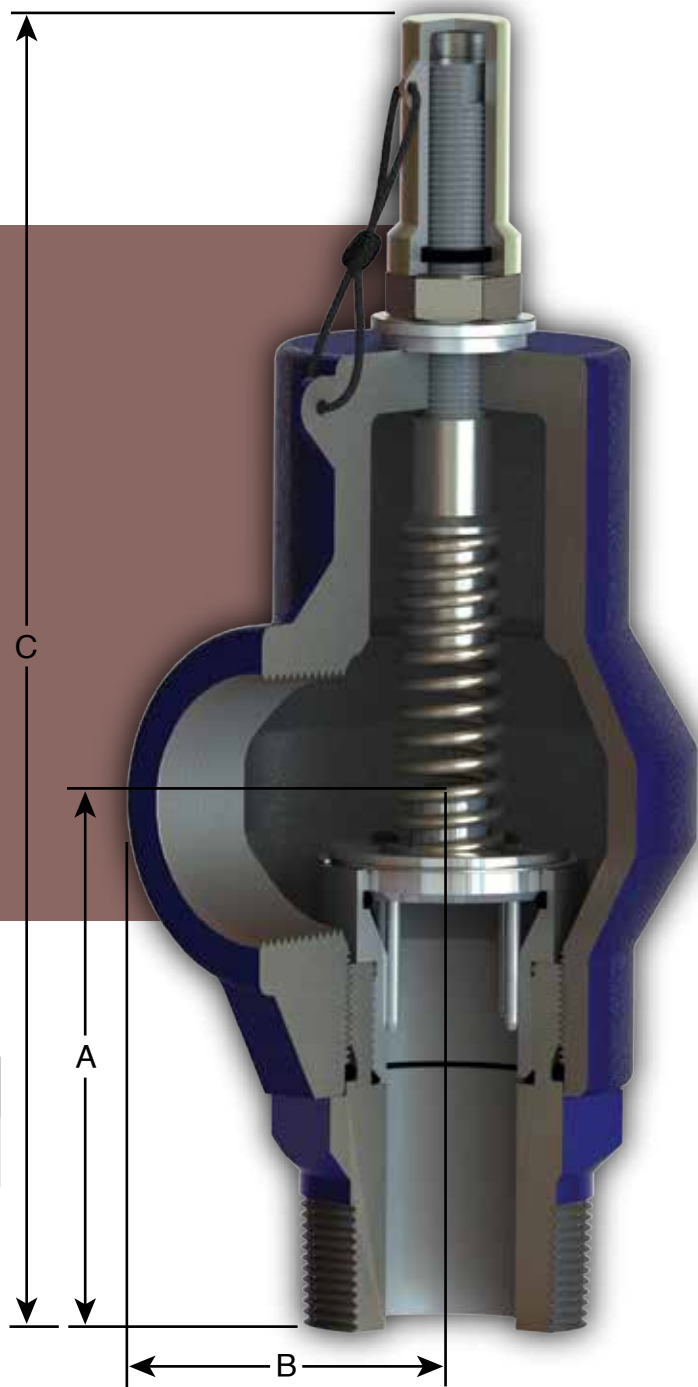

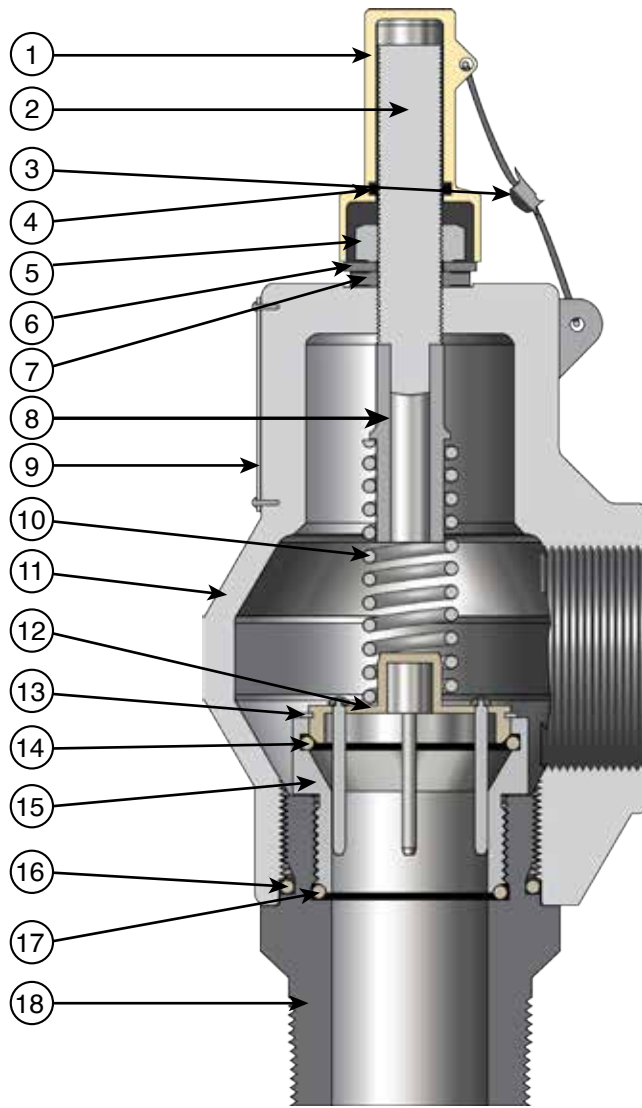

BILL OF MATERIALS

#	Part Description	Material	
		Standard	SS
1	Thread Protector	Steel	302 SS
2	Adjust Screw Assembly	Zinc CS	302 SS
3	Lead Seal & Wire	Steel	
4	"O" Ring	FKM	
5	Jam Nut	Steel	Steel
6	Washer	Steel	Steel
7	Thread Seal	Steel & FKM	
8	Spring Keeper	Steel	302 SS
9	Data Label		304 SS
10	Spring	17-7 SS	17-7 SS
11	Body	ASTM A216 WCC	
12	Disc Assembly		316 SS
13	Stop Ring		316 SS
14	Disc Seal	FKM	
15	Seat		316 SS
16	Body "O" Ring	FKM	
17	Seat "O" Ring	FKM	
18	Seat Frame	ASTM SA695 / SA36	

Alternate materials and connections available

VALVE PART NUMBERS

#	Spring	Size	Body & Seat Frame Material
84	01 Brown	01 1" MNPT x 1" FNPT	03 Carbon Steel
	02 Blue	02 2" MNPT x 2" FNPT	05 316 SS
	03 Yellow		
	04 Green		

Example: 84-020305

84	02 Blue	02 2" MNPT x 2" FNPT	05 316 SS
----	---------	----------------------	-----------

SPRING PART NUMBERS

Color	Size	
	1"	2"
Brown	05-001615	
Blue	05-001115	05-001115
Yellow	05-001215	05-001215
Green		05-001315

The information contained in these illustrations are the sole property of Taylor Valve Technology Inc. and any reproduction in part or whole without the written permission of Taylor Valve Technology Inc. is prohibited.

NOTE: Taylor Valve reserves the right to change product designs and specifications without notice.

