



Model DG

The **Model DG** is an inline valve that holds a bubble-tight, closed position until pressure reaches an exact set point. At set point, the pin buckles and the valve instantly opens to relieve pressure from a protected system.



Applications

The **Model DG** valve provides safety for a variety of pressure relief applications including but not limited to: Oil and Gas Production, Pipeline, Well Drilling, Chemical Processing, Food Processing, Waste Water Disposal, Pharmaceutical Processing, Pulp and Paper Plants, and anywhere that conventional relief valves and rupture discs are used.

Specs

Set Pressure: 5 - 2,000 Psig

Accuracy: + / - 5%

Connections: Standard and custom available.

Seals: Available for high & low temperatures, Viton standard.

Standard Materials: Body stainless-steel with standard stainless-steel trim, other materials optional.

The Pin

The pin is located outside the valve and is the heart of the operation, acting as the sensor and actuator. Once buckled, one person in under a minute can reset the pin in place without breaking the line.

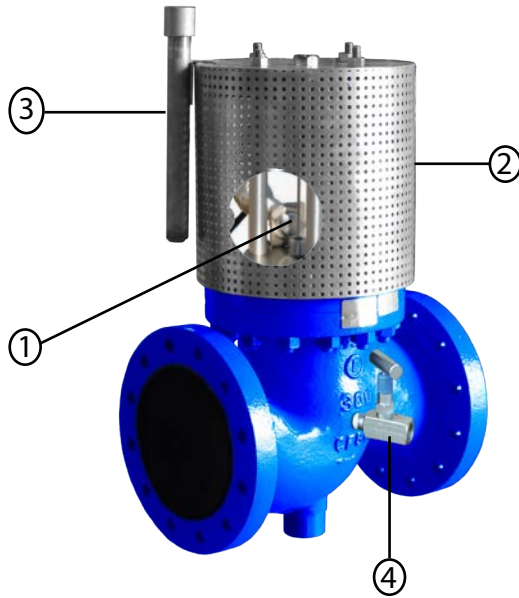

Options

Proximity Sensor (1)
Valves can be equipped with a proximity sensor that allows for remote monitoring of the valves status.

Stainless-steel Safety Cage (2)
Add a safety cage to protect against foreign objects from interfering with the operation of the pin.

Pin Container(3)
Pin containers are a great way to keep replacement pins ready to go right on the valve for when you need them.

Flush Port (4)
Add a flush port to relieve pressure or mount a pressure gauge.

Model DG-A Standard Pressure Relief

Closed

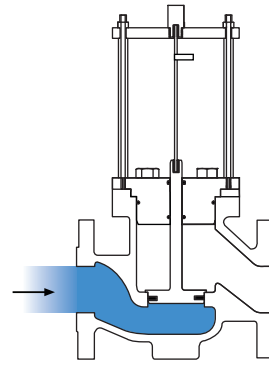

(Straight Pin)

Pressure below set point.

Open

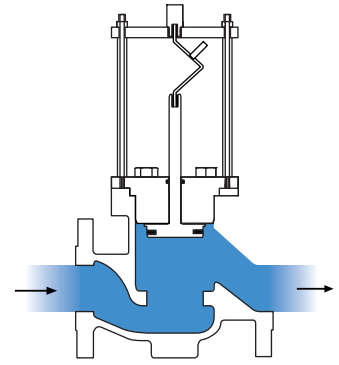

(Buckled Pin)

Pressure at set point.

Model DG-B Balanced Pressure Relief

Closed

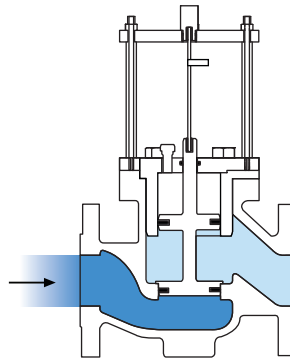

(Straight Pin)

Pressure below set point.

Open

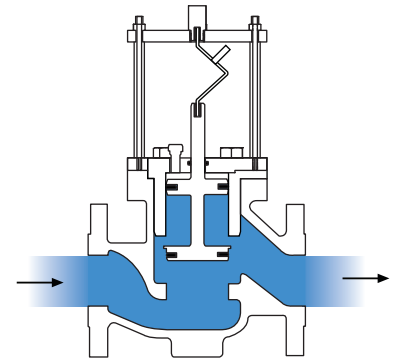

(Buckled Pin)

Pressure at set point.

Model DG-C Differential Pressure Relief

Closed

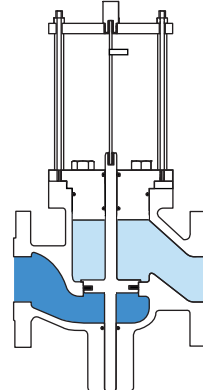

(Straight Pin)

Pressure below set point.

Open

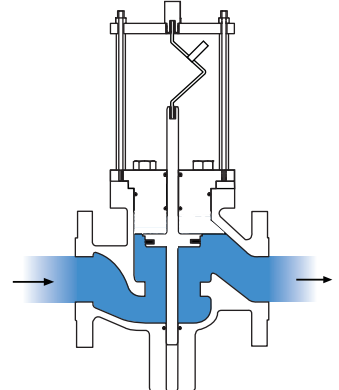

(Buckled Pin)

Pressure at set point.