



Rupture Pin<sup>®</sup> A BRAND of \_\_\_\_\_

Taylor Valve Technology<sup>®</sup>

GET THE **POWER** OF THE PIN

MODEL IC

# Mud and Slurry Relief Valve



FROM THE  
CREATORS  
OF THE  
*Original*  
BUCKLING  
PIN  
VALVE

Get Better Performance  
and Longer Life!

Lower your Downtime  
and Save Money!

Model IC

WWW.TAYLORVALVE.COM

SINCE 1958

## “POCO” Pin Design Variation

This intelligent design allows the user to change the set pressure of the valve by simply changing pins. This is done by affixing pin spacers on each end of the Rupture Pin while keeping the overall length of the pin assembly constant.

### Advantages

1002 and 1502 hammer unions.

Relief settings from 1,000 to 10,000 PSI with POCO set pressure pins. Set Pressure Tolerance: +/-5% when new from the factory.

Change the settings by changing the pin. The set pressure is shown on the pin label. The 3” Model IC valve uses the same interchangeable pins. In addition, the pins are color-coded accordingly.

Reliable settings.

Simple dependable operation.

One moving part.

Fatigue and pulsation are not factors that affect the set pressure of the valve.

Reaches open position in milliseconds.

Provides a bubble-tight seal to set point.

Stainless-steel seat and piston are standard.

Greater washout resistance with no direct impingement on the seat, piston or seal.

Field repairable.

Visual indication of opening.

Unaffected by changing ambient temperatures on the pin.

Pin cannot fatigue or buckle early.

No environmental exposure to process fluids.



### COLOR CODED PINS

Pins for the Mud Valve are color coded to show each individual set pressure.

#### MUD RELIEF VALVES - “POCO” PIN CHART\*

PIN TYPE	SIZE	COLOR
IC - 1,000 PSI	3”	BRONZE
IC - 1,500 PSI	3”	AQUA
IC - 2,000 PSI	3”	LT. GREEN
IC - 2,500 PSI	3”	GRAY
IC - 3,000 PSI	3”	GOLD
IC - 3,500 PSI	3”	BLACK
IC - 3,800 PSI	3”	WHITE
IC - 4,000 PSI	3”	DK. BLUE
IC - 4,500 PSI	3”	ORANGE
IC - 5,000 PSI	3”	DK. GREEN
IC - 5,500 PSI	3”	YELLOW
IC - 6,000 PSI	3”	RED
IC - 6,500 PSI	3”	LT. BLUE
IC - 7,000 PSI	3”	TAN
IC - 7,250 PSI	3”	Met. Bronze
IC - 7,500 PSI	3”	PINK
IC - 8,000 PSI	3”	SILVER
IC - 8,500 PSI	3”	FUCHSIA
IC - 9,000 PSI	3”	BROWN
IC - 9,500 PSI	3”	OLIVE
IC - 10,000 PSI	3”	PURPLE

\*For other set pressures, contact Taylor Valve.

## The Superior Mud & Slurry Relief Valve

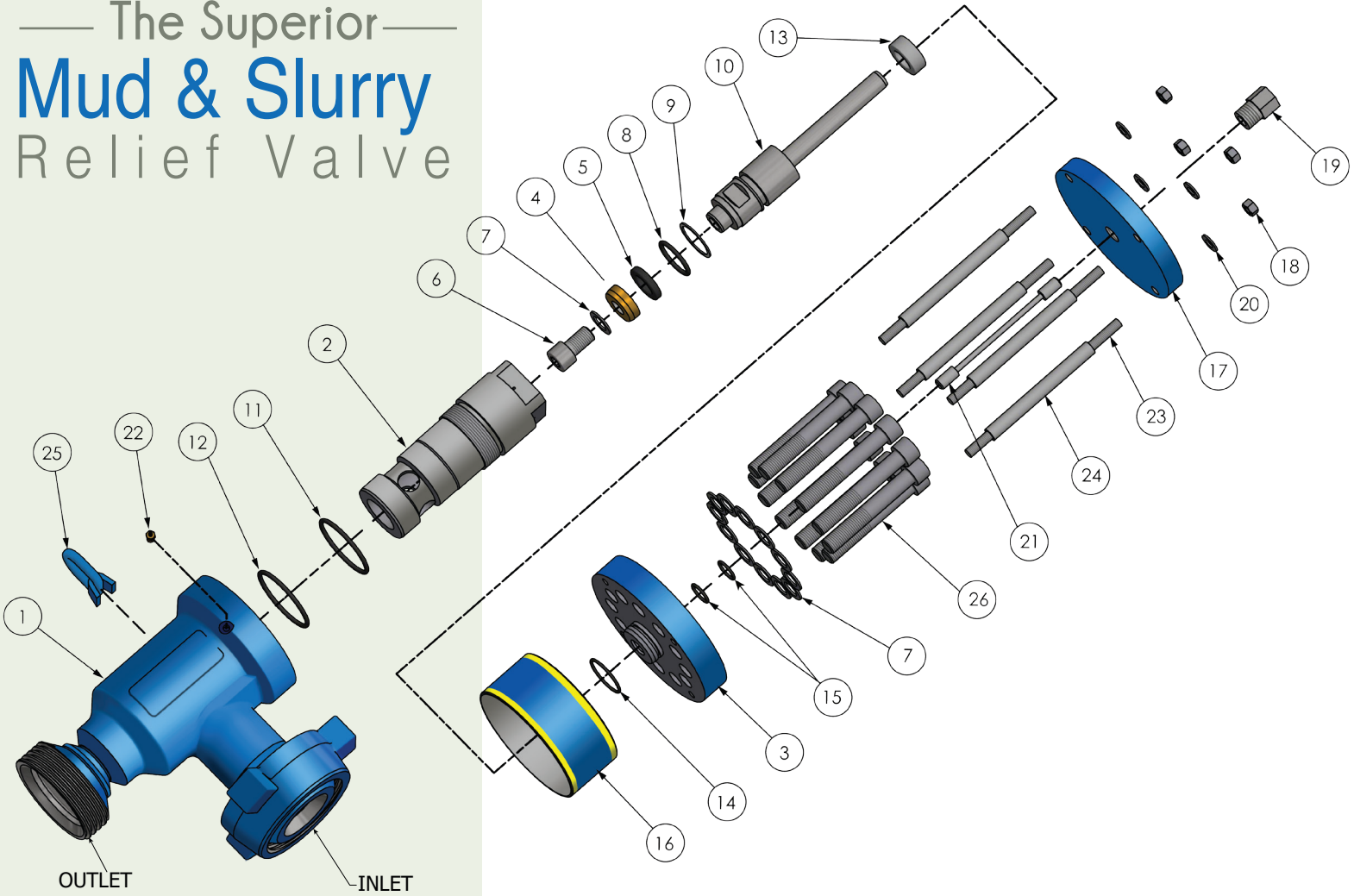

Parts List - MODEL IC

ITEM NO.	DESCRIPTION	QTY
1	BODY	1
2	SEAT CAGE	1
3	BONNET	1
4	SEAL RETAINER	1
5	MAIN SEAL	1
6	PISTON BOLT	1
7	WEDGE LOCK WASHER [BONNET]	12
8	O-RING [PISTON]	1
9	BACK-UP RING [PISTON]	1
10	PISTON	1
11	O-RING [UPPER CAGE]	1
12	O-RING [LOWER CAGE]	1
13	BUMPER	1
14	O-RING [BONNET]	1
15	O-RING [STEM]	2
16	SLEEVE	1
17	TOP PLATE	1
18	HEX NUT [TOP PLATE]	4
19	HOLDING NUT	1
20	WEDGE LOCK WASHER [TOP PLATE]	4
21	RUPTURE PIN	1
22	GREASE FITTING	1
23	POST	4
24	SPACER	4
25	LIFTING LUG	1
26	BONNET BOLT	12

### How It Works

Pressure acting on a differential piston area puts an axial force on the pin.

At an exact set point, the pin buckles and the valve opens in milliseconds for immediate pressure relief.

Relieves pressure to prevent pump, hose and system damage on mud and slurry pump systems - ideal for pulsating pressure.



## OPERATION

In the closed position, an elastomer seal contacts a machined, stainless-steel piston seat for a bubble-tight shut off.

When the pin buckles, the piston moves fully open in milliseconds to a protected position to allow full flow pressure relief.

Closed

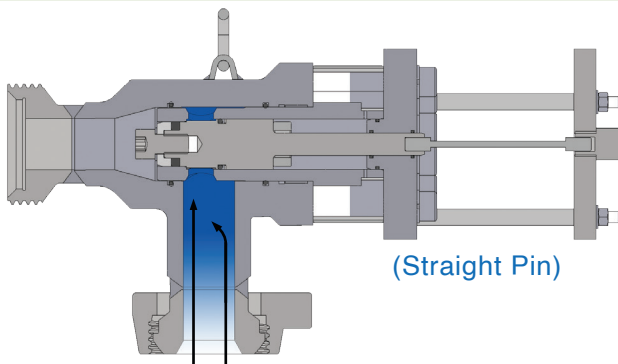

Open

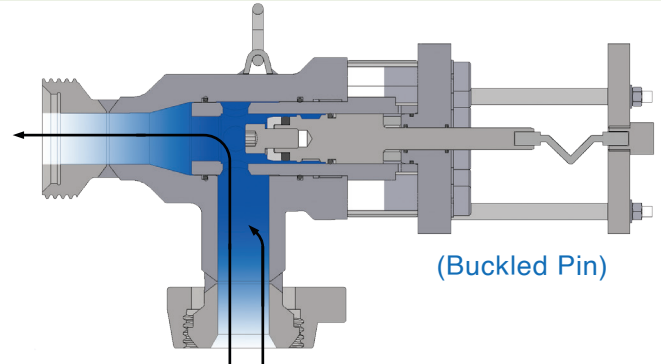

### STANDARD MATERIALS

Model IC: AISI 4130, Forged Body with stainless-steel trim. Other materials optional.  
*Drilling compatible seals.*

### CONNECTIONS

Standard and custom connections available.

### CERTIFICATIONS

Available with domestic offshore and international certifications and standards upon order request.

**Ready to drill FASTER & SAFER with LESS DOWNTIME than your competition?**  
**Let's get you using the best mud valve today!**  
**Call us at:**

## OPTIONS

1. STAINLESS-STEEL SAFETY CAGE
2. PIN CONTAINER
3. PROXIMITY SENSOR

